

# NEPAL ELECTRICITY AUTHORITY

(GOVERNMENT OF NEPAL UNDERTAKING)

**Medium Generation Operation and Maintenance department**

Trishuli Hydropower Station

**TRISHULI, NUWAKOT, NEPAL**



TENDER NO. THPS-073/74-M/ST-12

***Tender Document***

FOR

**RUNNER REPAIR WORKS FOR UNIT 3,5 (NCB)**

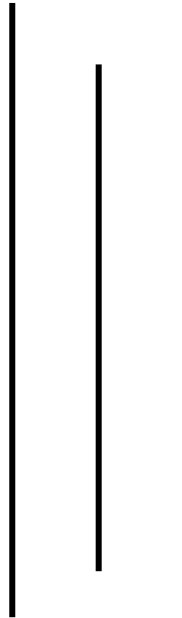

|                                  |     |                        |
|----------------------------------|-----|------------------------|
| LAST DATE AND TIME OF PURCHASING | : - | 2074/03/25, 17:00 HRS. |
| LAST DATE AND TIME OF SUBMISSION | : - | 2074/03/26, 12:00 HRS. |
| OPENING DATE & TIME              | : - | 2074/03/26, 14:00 HRS. |

**FY 2073/074**

**Section I – Invitation for bid**

**CONTENTS**

SECTION I - INVITATION FOR BID ..... 3

SECTION II Instruction to Bidders (ITB) ..... 5

SECTION III Bidding data sheet ..... 17

Section IV General Conditions of Contract ..... 27

Section V - Special Conditions of Contract ..... 38

Section VI - Schedule of Requirements ..... 44

Section VII - Works Requirements ..... 45

Section VIII - Bid forms, Price Schedule & Sample Forms ..... 53

    1. Quotation and Price Schedules ..... 53

    2. Bid Security ..... 55

    3. Form of Agreement ..... 57

    4. Performance Security ..... 58

    5. Bank Guarantee for Advance Payment ..... 59

    6. Manufacturer's Authorization Form ..... 60

    7. Declaration of Local Agent ..... 61



Section I – Invitation for bid

## SECTION I - INVITATION FOR BID

(First date of Publication: 2074/02/26)

1. Nepal Electricity Authority (NEA), Generation, Operation & Maintenance, Medium Electricity Operation & Maintenance Department, Trishuli Hydro Power Station invites wax Sealed Tenders from eligible bidders/manufacturers for works listed in the table below :

| Sealed Tender No:   | Work Description                 | Last date for Bid Purchase | Last date for Bid Submission | Bid Bond (Amount & Validity) |
|---------------------|----------------------------------|----------------------------|------------------------------|------------------------------|
| THPS-073/74-M/ST-12 | RUNNER REPAIR WORKS FOR UNIT 3,5 | 2074/03/25                 | 2074/03/26                   | NRs 80,000.00<br>120 days    |

2. A complete set of Bid Documents may be purchased during office hours on all working days by any interested Bidder from **2074/02/26** onwards upon submission of a written application to the addresses below accompanied by a bank voucher (non refundable) of **NRs. 3000.00** for **Sealed Tender** towards the cost of the Bid Documents deposited in **A/C of Trishuli Hydro Power Station, current account no: 018152'C'** at **Nepal Bangladesh Bank, Battar, Nuwakot** or **NEA, Generation current account no: 1206101001012524** held at **Nepal Rastra Bank, Banking Office, Thapathali, Kathmandu**. The Bid documents shall be available for sale up to one day before the last date of Bid submission as specified in Table above.
3. The Bidders must produce a **notarized copy** of the certificates of VAT registration and PAN registration and Tax Clearance Certificate (2072/73) or authorize process letter issued by Tax Revenue Office at the time of purchase of the Bid Documents.
4. All Bids accompanied by a Bid Bond of an amount with validity period specified above must be delivered in accordance with the Instructions to Bidders at or before **12:00** hour local time on or before the dates at **Office of Trishuli Hydropower Station, Trishuli, Nuwakot**. The Bids shall be opened at **14:00** hours local time on the same date of the Bid submission, in the presence (or without presence) of the authorised representatives of the Bidders who choose to be present. If the specified dates of Bid purchase, submission and opening fall on a public holiday, the same shall be done on the next working day.
5. NEA shall not be responsible for any costs or expenses incurred by Bidders in connection with the preparation or submission of Bids.
6. NEA reserves the right to accept or reject any Bid, partly or wholly, or cancel the Bids altogether, without assigning any reason whatsoever.
7. Interested eligible Bidders may obtain further information on the Bids or inspect the Bid Documents at the office given below or information pertaining to Bid and e-bidding from NEA's website <http://www.e-nea.org.np>
8. Any amendment in the tender notice shall be published in the NEA Web Portal

Nepal Electricity Authority  
Trishuli Hydropower Station,  
Trishuli, Nuwakot, Nepal.  
Tel./Fax : +977-010-560099

Nepal Electricity Authority  
Medium Generation, Operation and  
Maintenance Department,  
NEA, Durbarmarg, Kathmandu, Nepal  
Tel. : +977-01-4153081



Section I – Invitation for bid



## Nepal Electricity Authority

### Generation Directorate

(Publication Date 2074/02/26)

## National Competitive Bidding

Sealed Tenders/Quotation are invited for the following Schemes of Nepal Electricity Authority, Large & Medium Generation Operation & Maintenance Department (LGOMD & MGOMD)

| S. No.  | Works/Jobs (e-bid)   | Bid No.               | Sale of Bid Documents till date (Office time) | Last date of Bid Submission, Opening Time & Place                                      | Cost of Bid Documents (Bank deposit) | Bid Security/ Bid Bond (Bank Deposit/ Bank Guarantee) | Bid Documents available at   | Bank A/C No   |
|---|--|-----------------------|---|--|--------------------------------------|---|--|---|
| <b>Trishuli Hydro Power Station (THPS), Trishuli, Nuwakot</b>       |  |                       |   |  |                                      |   |  |   |
| 1   | Supply and Delivery of Lubricants and Consumables  | THPS-073/74-M/SQ-09   | Up to 2074/03/09                              | 2074/03/11 till 12:00 Noon & 02:00 PM, Trishuli Hydropower Station, Trishuli, Nuwakot. | Nrs. 500/-                           | Nrs. 22,000/-   | Medium Generation O. & M. Dept., Kathmandu & Trishuli Hydro Power Station, Trishuli, Nuwakot | Nepal Bangladesh Bank, Battar, Current A/C No. 018152 'C' |
| 2   | Runner Repair Works for Unit 3,5   | THPS-073/74-M/ST-11   | Up to 2074/03/25                              | 2074/03/26 till 12:00 Noon & 02:00 PM, Trishuli Hydropower Station, Trishuli, Nuwakot. | Nrs. 3,000/-                         | Nrs. 80,000/-   |  |   |
| <b>Kulekhani-I Hydro Power Station (KL-I), Dhorsing, Makwanpur.</b> |  |                       |   |  |                                      |   |  |   |
| 1   | Supply, Delivery, Installation, Testing and Commissioning of CCTV Cameraa and its accessories at Powerhouse of KL1 HPS | NEA-K11-073/74-ESQ-02 | Up to 2074/03/09                              | 2074/03/11 till 12:00 Noon & 02:00 PM, Kulekhani-I HPS, Dhorsing, Makwanpur            | Nrs.500/-                            | NRs. 15,500/-   | Large Generation O & M Dept, Kathmandu and KL-I HPS, Dhorsing                                | A/C No. 0101011651801, Nabil Bank Ltd., Hetaunda          |

For Further details and downloading of Bid Documents please visit our Website <http://www.nea.org.np> or Contact at 010-560423 (THPS), 057-410031 (KL-I), 01-4153070 (LGOMD) & 01-4153081 (MGOMD), 01-4153070 (LGOMD)



## Section II – Instruction to bidders

# SECTION II INSTRUCTION TO BIDDERS (ITB)

### A. Introduction

#### 1. **Scope of bid**

- 1.1 The Purchaser as defined in the Bidding Data invites Bids for Manufacturing, Fabrication, Installation and Commissioning of the goods, materials and equipment as described in bidding data (such goods, materials and equipment and related services hereinafter referred to as “Services”).
- 1.2 All Bids are to be completed and returned to the Purchaser in accordance with these Instruction to bidders

#### 2. **Sources of funds**

- 2.1 This contract is funded by Nepal Electricity Authority (NEA)'s own resources

#### 3. **Eligibility and qualification of bidders**

- 3.1 This Invitation for Bids is open to all eligible bidders, as indicated in the Bidding Data (Section III); & it is NCB.
- 3.2 Bidders should not be associated, or have been associated in the past, directly or indirectly, with a firm or any of its affiliates which have been engaged by the Purchaser to provide consulting services for the preparation of design, specifications, and other documents to be used for the procurement of goods to be purchased under this Invitation for Bid.
- 3.3 Government-owned enterprises may participate only if they are legally and financially autonomous, if they operate under commercial law, and if they are not a dependent agency of the Purchaser.
- 3.4 Bidder shall not be under a declaration of ineligibility for corrupt and fraudulent practices issued by GON and or the donor agency in accordance with Sub- Clause 41.1 and Sub Clause 43.2
- 3.5 All Bidders shall provide in Section VIII, Forms of Bid and Qualification Information, and criteria, technical production and financial capability a preliminary description of the proposed work method and schedule, including drawings and charts, as required in the Qualification Information.
- 3.6 If the Employer has not undertaken prequalification of potential Bidders, all Bidders shall include the following information and documents with their Bids, as Mandatory as specified in the BIDDING DATA.
  - a. copies of original documents defining the constitution or legal status, place of registration, and principal place of business; written power of attorney of the signatory of the bid to commit the Bidder;
  - b. total monetary value of contract work performed for each of the last five years;
  - c. experience in works of a similar nature and size for each of the last five years, be contacted for further information on those contracts (to comply with this requirement, works cited shall be at least 80% complete);
  - d. reports on the financial capacity of the Bidder, such as Audited Balance sheet, profit and loss statements and auditor's reports for the past three fiscal years;
  - e. evidence of adequacy of working capital for this Contract (access to line(s) of credit and availability of other financial resources);
  - f. authority to seek references from the Bidder's bankers;
  - g. power of attorney;
  - h. valid quality ISO Certificate as required by specification; and
  - i. At least two no. of end user's valid certificates.
  - j. Workshop facility with required machinery and equipment for satisfactorily repair and maintenance of the contract job.

**\*\*\* Conditions to the Bidder/Manufacturer in this document will also apply equally to the eligible Repair service provider \*\*\***



## Section II – Instruction to bidders

### 4. Eligible goods and services

- 4.1 All Goods and related services to be supplied under the Contract shall have their origin in eligible source countries as specified in Sub - Clause 3.1 and all expenditures made under the contract will be limited to such goods and services.
- 4.2 For purposes of this Clause, “origin” shall be considered to be the place where the Goods are mined, grown, produced or from which the Services are provided. Goods are produced when, through Manufacturing, processing, or substantial and major assembly of Components, a commercially-recognized product results that is substantially different in basic characteristics or in purpose or utility from its components.
- 4.3 The origin of goods and services is distinct from the nationality of the Bidder.

### 5. Cost of Bidding

- 5.1 The Bidder shall bear all costs associated with the preparation and delivery of its Bid, and the Purchaser will in no case be responsible or liable for those costs, regardless of the conduct or outcome of the bidding process.

### 6. One Bid per Bidder

- 6.1 Each Bidder shall submit only one bid, either individually or as a partner in a joint venture. A Bidder who submits or participates in more than one bid shall cause all the proposals with the Bidder's participation to be disqualified.

### 7. Bids submitted by a Joint Venture

- 7.1 Bids submitted by a joint venture of two or more firms as partners shall comply with the following requirements, unless otherwise stated in the Bidding Data:
  - a. Original of Joint Venture agreement legally binding on all JV Partner shall be included in the Bid. The joint Venture agreement shall bear the seal of the entities and signatures of personnel authorized by the respective entities forming the joint venture. All such authorization documents shall also be included in the Bid. These Authorization documents shall be on the original letterhead of the respective entity with stamp/seal of the entity.
  - b. The number of joint venture partners shall not exceed three (3).
  - c. The Partners of the JV shall be manufacturers or bidders. Each of the Partners of the JV shall be legally registered for at least five (5) years for conduction business similar to the one for which the Bid is invited.
  - d. Notarized copies of legal registration certificates for each JV partners shall be submitted along with the Bid.

### 8. Assurance

- 8.1 The successful Bidder will be required to give satisfactory assurance of its ability and intention to supply the Goods pursuant to the Contract, within the time set forth therein.

## B. The Bidding Documents

### 9. Content of Bidding Documents

- 9.1 The Goods required, bidding procedures, and contract terms are prescribed I the Bidding Documents. In addition to the invitation of bids, the Bidding Documents include:
  - a. Instructions to Bidders (ITB)
  - b. Bidding Data (BD)
  - c. General Conditions of Contract (GCC)
  - d. Special Conditions of Contract (SCC)
  - e. Schedule of Requirements (SOR)
  - f. Technical Specifications and Drawing (T Spec) including Technical data sheet
  - g. Bid Form and Price Schedules, including Bidder's qualification Requirement
  - h. Bid Security Form
  - i. Contract Form



## Section II – Instruction to bidders

- j. Performance Security Form
- k. Bank Guarantee Form for Advance Payment
- l. Manufacturer's Authorization Form. (if any)
- m. Addendum issued in accordance with Sub - Clause 11, if any.

9.2 The Bidder is expected to examine the Bidding Documents, including all instructions, forms, terms, specifications and drawings. Failure to furnish all information required by the Bidding Documents or submission of a Bid not substantially responsive to the Bidding Documents in every respect will be at the bidder's risk and may result in the rejection of its Bid.

### 10. Clarification of bidding documents

10.1 prospective Bidder requiring any further information or clarification of the Bidding Documents may request the Purchaser in writing or by fax at the purchaser's address indicated in the Bidding Data The Purchaser will respond in writing or by fax to any request for information or clarification of the Bidding Documents which it receives no later than fifteen (15) days prior to the deadline for the submission of Bids prescribed in Sub-Clause 24.1. The Purchaser's response (including an explanation of the query) will be sent in writing or by fax to all prospective bidders who have purchased the Bidding Documents.

### 11. Amendment of bidding documents

- 11.1 At any time prior to the deadline for submission of bids, the Purchaser may, for any reason, whether at its own initiative or in response to a clarification requested by a prospective bidder, shall amend or modify the Bidding Documents by issuing the addenda.
- 11.2 The amendment shall be part of the Bidding Documents, pursuant to Sub-Clause 9.1, will be notified in writing or by fax to all prospective Bidders who have purchased the Bidding Documents.
- 11.3 In order to allow prospective Bidders reasonable time in which to take the amendment into account in preparing their Bids, the Purchaser may, at its discretion, extend the deadline for the submission of Bids in accordance with Sub - Clause 24.2.

## C. Preparation of Bids

### 12. Language of Bid

12.1 The Bid prepared by the Bidder, and all correspondence and documents relating to the Bid exchanged by the Bidder and the Purchaser, shall be written in the language specified in Bidding Data.

### 13. Documents Comprising the Bid

- 13.1 The Bid prepared by the Bidder shall comprise the following components:
  - a. Bid Form and a Price Schedule completed in accordance with Clauses 14, 15, and 16;
  - b. documentary evidence established in accordance with Clause 17, that the Bidder is eligible to Bid and that the Goods and Services to be supplied by the Bidder are eligible under the contract;
  - c. documentary evidence established in accordance with Clause 18, that the Bidder is qualified to perform the contract if its Bid is accepted;
  - d. documentary evidence established, in accordance with Clause 19, that the Goods and services to be supplied by the Bidder are genuine and newly manufactured goods and conform to the Bidding Documents;
  - e. Bid security furnished in accordance to Clause 20;

### 14. Bid Form

14.1 The Bidder shall complete the Bid Form and the appropriate Price Schedule furnished in the Bidding documents, indicating the goods to be supplied, a brief description of the goods, their country of origin, quantity and prices.

### 15. Bid Prices.

15.1 The Bidder shall complete the appropriate Price Schedule and the sources of Goods schedules included herein, stating the unit prices, total cost per item, the total Bid amount and the expected countries of origin of the Goods to be supplied under the contract.



## Section II – Instruction to bidders

- 15.2 Prices quoted in the Price Schedules should be entered separately in the following manner:
- the price of the goods quoted EXW (ex works, ex factory, ex warehouse, ex showroom, or off-the-shelf, as applicable), excluding custom duty and VAT, if applicable, which shall be paid by the purchaser.
  - the price for inland transportation, insurance, and other local costs incidental to delivery of the goods to their final destination, if specified in the Bidding Data .
  - the price of Installation, field testing and commissioning, as listed in the Bidding Data
- 15.3 Price quoted by the Bidder shall remain fixed and valid until completion of the contract performance and will not be subject to variation on any account.
- 15.4 The terms EXW, FOB, CIF, CIP, etc., shall be governed by the rules prescribed in the current edition of INCOTERMS published by the International Chamber of Commerce, Paris.
- 15.5 The Bidder's separation of price components in accordance with Clause 15.1 above will be solely for the purpose facilitating the comparison of bids by the Purchaser and will not in any way limit the Purchaser's right to contract on any of the terms offered.
- 15.6 If the Bidder intends to offer any discount, it should always be expressed in fixed percentage and that will not vary as the quantities varies and be applicable to each unit rate
- 15.7 A foreign Bidder wishing to have or already having a local agent should state the following:
- Name and address of the Agent/Representative,
  - The Agent/Representative providing type of services,
  - Amount of commission if the Agent/ Representative is entitled to get such payment and if he/she participate in the procedure of payment,
  - Other agreement with Agent/Representative, if any,
  - should certify in the Letter of Authorization as follows:“ We certify that the statement and disclosure made by us on the above are complete and true to the best of our knowledge and belief”
- If the agent has not been appointed:
- Source of information about tender invitation,
  - remuneration given to the individual or firm/company or organization to work on his behalf for submitting tender, representation in the bid opening and other required action in connection with the tender,
  - Transfer or handover an evidence of foreign currency exchanged which required to be submitted with the tender,
  - If the bank account of any Nepali citizen has been used for the exchange of foreign currency specify the name of the individual and his address. If the foreign currency has been exchanged by self then the certificate of currency exchange.
- 15.8 If a foreign Bidder in his Bid, has not provided the information mentioned in Sub Clause 15.7 or has submitted his bid stating that the Bidder does not have local agent and later it is proved that the bidder has a local agent or it is proved that the commission mentioned in the Bid is less than the commission received by the local agent then the Purchaser shall initiate proceedings to black list such bidder.
- 15.9 Bid submitted with an adjustable price quotation shall be treated as nonresponsive bid and rejected.
- 15.10 The bidder shall quote in BOQ, excluding custom duty and VAT, which shall be paid by the purchaser himself and reimburse afterward.

## 16. Currency of Bid

- 16.1 Prices shall be quoted in Nepalese Rupees or as specified in Bidding Data

## 17. Documents establishing eligibility of the bidders

- 17.1 Pursuant to Sub - Clause 13, the Bidder shall furnish, as part of its Bid, documents establishing the Bidder's eligibility to Bid and that the country of origin of the Goods is from eligible source country.
- 17.2 Pursuant to Sub - Clause 13, the Bidder shall furnish, as part of its Bid, documents establishing the eligibility to the Bidding Documents of all Goods and Services which the bidder proposes to supply under the contract.



## Section II – Instruction to bidders

### 18. Establishing the Bidder's Qualifications to Perform the Contract

- 18.1 The documentary evidence of the Bidder's qualifications to perform the contract, if its Bid is accepted, shall establish to the Purchaser's satisfaction:
- that, in the case of a Bidder offering to supply Goods under the contract which the Bidder did not manufacture or otherwise produce, the Bidder has been duly authorized solely by the Goods' Manufacturer or Producer to supply and install the Goods in Nepal;
  - that the Bidder has the financial, technical and production capability necessary to perform the contract, including capacity in terms of personnel for the purpose of carrying out the services; and
  - Bidder is, or will be (if the contract is awarded to it), represented by an agent in Nepal, who shall be capable to Fulfill the contractual obligations regarding :
    - maintenance and repair of the supplied goods /services,
    - after sales service,
    - maintains stock for supply of spare parts
  - that, the Bidder in the last three years (3) has supplied Goods of nature quantity and of contract amount to government enterprises or private institutions as specified in the Bidding Data
  - that the Bidder meets the qualification criteria listed in Bidding Data and Qualification Requirements of bidders .

### 19. Documents Establishing the Good's Conformity to the Bidding Documents

- 19.1 Pursuant to Clause 13, the Bidder shall furnish, as part of its Bid, documents establishing the eligibility and conformity to the Bidding documents of all goods and services which the Bidder proposes to supply under the contract.
- 19.2 Documentary evidence of the eligibility of the goods and services shall consist of a statement in the Price Schedule of the country of origin of the goods and services offered which shall be confirmed by a certificate of origin issued at the time of shipment.
- 19.3 The documentary evidence of the conformity of Goods and Services to the Bidding Documents may be in the form of literature, drawings and data and shall consists of:
- a detailed description of the essential technical and performance characteristics of the goods;
  - a list, giving full particulars, including available sources and current prices, of all spare parts, special tools, etc, necessary for the proper and continuing functioning of the Goods for a period to be specified in the Bidding Data, following commencement of the use of the goods by the Purchaser; and
  - an item by item commentary and the Technical Specifications demonstrating substantial responsiveness of the goods and services to those specifications, or a statement of deviations and exceptions to the provisions of the Technical Specifications;
  - a detailed schedule of execution of works under the contract (works schedule), outlining key activities and the critical items on the schedule which could influence the contract completion date.
- 19.4 For the purposes of the commentary to be furnished pursuant to Sub- Clause 19.3 (c) above, the Bidder shall note that standards for workmanship, material, and equipment, as well as references to brand names or catalogue numbers designated by the Purchaser in its Technical Specifications, are intended to be descriptive only and not restrictive. The Bidder may substitute alternative standard, brand names, and/or catalogue numbers in its Bid, provided that it demonstrates to the Purchaser's satisfaction that the substitutions are equivalent or superior to designate in the Technical Specifications, except if the Technical Specifications specifically provide otherwise.
- 19.5 The bidder shall fill the bid firms as specified in bidding data.

### 20. Bid security

- 20.1 Pursuant to Sub - Clause 13, the Bidder shall furnish, as part of its Bid, a Bidsecurity in Nepali Rupees in the amount of not less than NRs.76,000.00 as specified in the Bidding Data .
- 20.2 The Bid security shall be denominated in the currency of the Bid and shall be valid for thirty (30) days beyond the validity of the Bid. The Bid Security, at the Bidder's option, shall be in the form of earnest money, bank draft, or a bank guarantee from a reputable bank in Nepal acceptable to the Employer or from a reputable foreign bank which is endorsed by the local bank in Nepal acceptable to the

## Section II – Instruction to bidders

- Employer. The format of the bank guarantee shall be in accordance with the form of bid security included in Section VIII; other formats may be permitted, subject to the prior approval of the Employer.
- 20.3 Any Bid not secured in accordance with Sub - Clauses 20.1 and 20.2 above will be rejected by the Purchaser as non-responsive, pursuant to Clause 29
- 20.4 Unsuccessful bidders' bid securities will be discharged or returned within three(3) days after signing the contract with the successful bidder.
- 20.5 successful Bidder's bid security will be discharged or returned, or both, upon the Bidder signing the contract, pursuant to Clause 39, and furnishing the performance security pursuant to Clause 40.
- 20.6 Bid security shall be forfeited:
- a. if a Bidder:
    - i. withdraws its Bid during the period of Bid validity specified by Bidder on the Bid Form, or
    - ii. does not accept the correction of errors pursuant to Sub -Clause 29.2; or
  - b. in case of a successful Bidder, if the Bidder fails within the time limit to :
    - i. sign the contract in accordance with Sub - Clause 39; or
    - ii. furnish the performance security in accordance with SubClause 40.

### 21. Period of validity of bids

- 21.1 Bids shall remain valid for the period specified in the Bidding Data after the date of Bid submission prescribed by the Purchaser, pursuant to Sub - Clause 24. A bid valid for a shorter period shall be rejected by the Purchaser as non-responsive
- 21.2 In exceptional circumstances, the Purchaser may solicit Bidder's consent to an extension of the period of Bid validity. The request and the responses thereto shall be made in writing (or by cable). If the Bidder agrees to the extension request, the validity of the Bid security provided under Clause 20 shall also be suitably extended. A Bidder may refuse the request without forfeiting its Bid security. A Bidder granting the request will not be required nor permitted to modify its Bid.

### 22. Format and Signing of Bid

- 22.1 The bidder shall prepare one original of the documents comprising the Bid as described in Clause 13, bound with the volume containing the Form of Bid and Price Schedule, and clearly marked "Original", in addition, the Bidder shall submit one copy of the Bid clearly marked "Copy". In the event of any discrepancy between the original and the copy, the original shall govern.
- 22.2 The original and copy of Bid shall be typed or written in indelible ink and shall be signed by the Bidder or a person or persons duly authorized to sign on behalf of the Bidder. Such Authorization shall be indicated by written power-of-attorney accompanying the Bid. All pages of Bid shall be initialed by the person or persons signing the Bid.
- 22.3 The bid shall contain no inter lineation, erasures or overwriting, alterations or additions except as necessary to correct errors made by the Bidder or those to comply instructions issued by the Purchaser, in which case, such corrections shall be initialed by the person or persons signing the bid.

## D. Submission of bids

### 23. Sealing and marking of bids

- 23.1 The Bidder shall seal the original and each copy of the Bid in separate envelopes, duly marking the envelopes as "ORIGINAL" and "COPY." The envelopes shall then be sealed in an outer envelope.
- 23.2 The inner and outer envelopes shall:
- a. Be addressed to the Purchaser at the address given in the Bidding Data ; and
  - b. Bear the tender name indicated in the Bidding Data the Invitation for Bids title and number indicated in the Bidding Data, and a statement: "DO NOT OPEN BEFORE....." to be completed with the time and the date specified in the Bidding Data pursuant to Clause 27
- 23.3 The outer envelopes shall also indicate the name and address of the Bidder to enable the Bid to be returned unopened in case it is declared "late"



## Section II – Instruction to bidders

23.4 If the outer envelope is not sealed and marked as required by Clauses 23.1 and 23.2, the Purchaser will assume no responsibility for the Bid's misplacement or premature opening.

### 24. Deadline for submission of bids

24.1 The Bid must be received by the Purchaser at the address specified under ITB Clause 23.2 no later than the time and date specified in the Bidding Data.

24.2 The Purchaser may, at its discretion, extend this deadline for the submission of Bids by amending the Bidding Documents in accordance with Clause 11, in which case all rights and obligations of the Purchaser and Bidders previously subject to the deadline will thereafter be subject to the deadline as extended.

### 25. Late bids

25.1 Any Bid received by the Purchaser after the deadline for submission of Bids prescribed by the Purchaser, pursuant to Clause 24, will be declared "Late bid" and rejected and returned unopened to the Bidder.

### 26. Modification and withdrawal of bids

26.1 The Bidder may modify or withdraw its Bid after the Bid's submission, provided that written notice of the modification or substitution or withdrawal is received by the Purchaser 24 hours prior to deadline for submission of Bids prescribed in Clause 24.

26.2 The Bidder's modification or withdrawal notice shall be prepared, sealed, and marked and dispatched in accordance with the provisions of Clause 23 and 26.1 with the outer and inner envelopes duly marked as "WITHDRAWAL" or "MODIFICATION" as appropriate.

26.3 No Bid may be withdrawn, modified after reaching the for submission of Bids.

26.4 No Bid may be withdrawn in the interval between the 24 hr due date before deadline for submission of Bids and the expiration of the period of Bid validity specified by the Bidder on the Bid Form. Withdrawal of a Bid during this interval may result in the Bidder's forfeiture of its Bid security, pursuant to the Sub - Clause 20.6a (i).

26.5 Bidder's may only offer discounts or otherwise modify the prices of their bids by submitting Bid Modifications in accordance with Clause 26, or included in the original bid submission.

## E. Bid opening and evaluation

### 27. Bid opening

27.1 The Purchaser will open all Bids in the presence of Bidder's representatives who choose to attend, at the time, date, and place as specified in the Bidding Data The Bidder's representatives who are present shall sign a register evidencing their attendance.

27.2 First, envelopes marked "WITHDRAWAL" shall be opened, read out and recorded and the envelope containing the corresponding bid shall not be opened, but return to the bidder. No bid shall be withdrawn unless the corresponding Withdrawal Notice contains a valid authorization to request the withdrawal and is read out and recorded at bid opening.

27.3 Next, envelopes marked "MODIFICATION" shall be opened, read out and recorded with the corresponding bid. No bid shall be modified unless the corresponding Modification Notice contains a valid authorization to request the modification and is read out and recorded at bid opening. Only envelopes that are opened, read out and recorded at bid opening shall be considered further.

27.4 The Bidders' names, Bid modifications or withdrawals, Bid prices, discounts and alternative offers, and the presence or absence of requisite Bid security and such other details as the Purchaser, at its discretion, may consider appropriate, will be announced and recorded at the opening. No Bid shall be rejected at Bid opening, except for late Bids, which shall be returned unopened to the Bidder pursuant to Clause 25 and 27.2.

27.5 The Purchaser will prepare minutes of the Bid opening indicating all remarks containing the name of the bidder, description of bid like modification or substitution or withdrawal, bid prices indicating the alternative bid prices if requested and discount offered if any, presence and absence of bid security, about late bids and other details as the Purchaser may consider appropriate. This minutes of bid opening shall duly signed by the Bidder and/or its representatives.



## Section II – Instruction to bidders

### 28. Clarification of bids

28.1 To assist in the examination, evaluation and comparison of Bids, the Purchaser may, at its discretion, ask the Bidder for a clarification of its Bid. The request for clarification and the response to it shall be in writing, and no change in the prices and substance of the Bid shall be sought, offered, or permitted, except as required to confirm the correction of arithmetic errors discovered by the Purchaser in the evaluation of the bid.

### 29. Examination of bids and determination of responsiveness

29.1 Prior to detail evaluation Bids, the Purchaser will determine whether each bid

- a. Meets the eligibility criteria defined in Clause 3 ;
- b. Has been properly signed;
- c. Is accompanied by required securities;
- d. The Purchaser will examine the Bids to determine whether they are complete, whether any computational errors have been made, whether is substantial responsive to the requirements of the Bidding documents.

29.2 Arithmetical errors will be rectified on the following basis. If there is a discrepancy between the unit price and the total price that is obtained by multiplying the unit price and quantity, the unit price shall prevail, and the total price shall be corrected. If there is a discrepancy between words and figures, the amount in words will prevail. If the Supplier does not accept the correction of the errors, its Bid will be rejected, and its Bid security may be forfeited.

29.3 Prior to the detailed evaluation, pursuant to Clause 31, the Purchaser will determine the substantial responsiveness of each Bid to the Bidding Documents. A substantially responsive Bid is one which conforms to all the terms and conditions of the Bidding Documents without material deviations. The Purchaser's determination of a Bid's responsiveness is to be based on the contents of the Bid itself without recourse to extrinsic evidence. A material deviation or reservation is one:

- a. which effects in any substantial way the scope, quality, or performance of the Contract;
- b. which limits in any substantial way, inconsistent with the Bidding documents, the Purchaser's right or the Bidder's obligations under the Contract; or
- c. Whose rectification would affect unfairly the competitive position of the other Bidders presenting substantially responsive bids.

29.4 The Purchaser may waive any minor informality, nonconformity, or irregularity in a Bid which does not constitute a material deviation, provided such waiver does not prejudice or affect the relative ranking of any Bidder.

29.5 A Bid determined as not substantially responsive will be rejected by the Purchaser and not subsequently be made responsive by the Bidder by correction or withdrawal of non-confirming deviation or reservations.

### 30. Process to be confidential

30.1 Information relating to the examination, clarification, evaluation and comparison of bids and recommendations for the Award of Contract shall not be disclosed to Bidders or any other persons not officially concerned with such process until the Award to the successful Bidder has been announced.

### 31. Evaluation and comparison of bids

31.1 The Purchaser will evaluate and compare the Bids which have been determined to be substantially responsive, pursuant to Clause 29.

31.2 The Purchaser's evaluation of a Bid will be in the base of Bid Price as specified in the Price Schedule.

31.3 The Purchaser reserves the right to accept or reject any variation, deviation, or alternative offer. Variations, deviations, and alternative offers and other factors which are in excess of the requirements of the Bidding Documents or otherwise result in unsolicited benefits for the purchaser will not be taken into account in Bid evaluation

31.4 The Purchaser's evaluation of a Bid will take into account, in addition to the Bid price quoted in accordance with Clause 15, one or more of the following factors in the manner and to the extent as specified in the Bidding Data and if quantified in Clause 31.6:



## Section II – Instruction to bidders

- (a) cost of inland transportation, insurance, and other costs within Nepal incidental to delivery of the goods to their final destination
- (b) delivery schedule offered in the Bid;
- (c) deviations in payment schedule from that specified in the Special Conditions of Contract
- (d) the cost of components, special tools, spare parts, and service;
- (e) the availability of spare parts in Nepal and after-sales services for the equipment offered in the Bid;
- (f) the projected operating and maintenance costs during the life of the equipment and/ or ;
- (g) other specific criteria indicated in the Bidding Data and/or in the Technical Specifications.

31.5 Comparison of Bids will be between the main Bids only unless otherwise specified in the Bidding Data

31.6 For factors retained in the Bidding Data pursuant to Sub -Clause 31.4, one or more of the following quantification methods will be applied, as detailed in the Bidding Data:

- a. Inland transportation from EXW/port of entry/border point, insurance, and incidentals. Inland transportation, insurance, and other incidental costs for delivery of the goods from EXW/port of entry/border point to Project Site named in the Bidding Data will be computed for each Bid by the Purchaser on the basis of published tariffs by the rail or road transport agencies, insurance companies, and/or other appropriate sources. To facilitate such computation, Bidder shall furnish in its Bid the estimated dimensions and shipping weight and the approximate EXW/CIF (or CIP border point) value of each package. The above cost will be added by the Purchaser to EXW/CIF/CIP border point price
- b. Delivery schedule: The Goods covered under this Invitation are required to be delivered (shipped) within an acceptable range of weeks specified in the Schedule of Requirement. No credit will be given to earlier deliveries, and bids offering delivery beyond this range will be treated as non-responsive. Within this acceptable range, an adjustment per week, as specified in the Bidding Data will be added for evaluation to the Bid Price of bids offering delivery later than the Earliest Delivery Period specified in the Schedule of Requirements.
- c. Deviation in payment schedule: bidders shall state their Bid price for the payment schedule outlined in the SCC. Bids will be evaluated on the basis of this base price. Bidders are, however, permitted to state an alternative payment schedule and indicate the reduction in Bid price they wish to offer for such alternative payment schedule. The Purchaser may consider in evaluation the alternative payment schedule offered by the selected Bidder and evaluate by adjusting the bid price accordingly if specified in the Bidding Data
- d. Cost of spare parts: The list of items and quantities of major assemblies, components, and selected spare parts, likely to be required during the initial period of operation specified in the Bidding Data is annexed to the Technical Specifications. The total cost of these items, at the unit prices quoted in each bid, will be added to the Bid Price
- e. Spare parts and after sales service facilities in Nepal. The cost to the Purchaser of establishing the minimum service facilities and parts inventories, as outlined in the Bidding Data or elsewhere in the Bidding documents, if quoted separately, shall be added to the Bid price
- f. Operating and maintenance costs. Since the operating and maintenance costs of the goods under procurement form a major part of the life cycle cost of the equipment,

## Section II – Instruction to bidders

these costs will be evaluated in accordance with the criteria specified in the Bidding Data or in the Technical Specifications.

- g. Specific additional criteria: Other specific additional criteria to be considered in the evaluation and the relevant evaluation method shall be as detailed in the Bidding Data and/or in the Technical Specification.

### 32. Domestic preference

As specified in bid data

### 33. Contacting the purchaser

- 33.1 Subject to Clause 28, no Bidder shall contact the Purchaser on any matter relating to its bid, from the time of the bid opening to the time the Contract is awarded. If the Bidder wishes to bring additional information to the notice of the Purchaser, it should do so in writing.
- 33.2 Any effort by a Bidder to influence the Purchaser in the Purchaser's bid evaluation, bid comparison or contract award decisions may result in the rejection of the Bidder's bid.

## F. AWARD OF CONTRACT

### 34. Post qualification

- 34.1 In the absence of prequalification, the Purchaser will determine to its satisfaction whether the Bidder that is selected as having submitted the lowest evaluated responsive Bid is qualified to perform the contract satisfactorily, in accordance with the criteria listed in Sub Clause 18.1.
- 34.2 The determination will take into account the Bidder's financial, technical, and production capabilities. It will be based upon an examination of the documentary evidence of the Bidder's qualifications submitted by the Bidder, pursuant to Clause 18.1, as well as such other information as the Purchaser deems necessary and appropriate.
- 34.3 To verify its technical and production capability the Bidder shall provide with its Bid documentary evidence that the items offered have been in production and have been in satisfactory operation as specified in bidding data

### 35. Award criteria

- 35.1 Subject to Clause 37, the Purchaser will award the contract to the successful Bidder whose Bid has been determined to be substantially responsive and has been determined to be the lowest evaluated Bid, provided further that the Bidder is determined to be qualified to perform the contract satisfactorily.

### 36. Purchaser's Right to Vary Quantities at Time of Award

- 36.1 The Purchaser reserves the right at the time of contract award to increase or decrease, by the percentage indicated in the Bidding Data, the quantity of goods and services originally specified in the Schedule of Requirements without any change in unit price or other terms and conditions.

### 37. Purchaser's Right to Accept Any Bid and to Reject Any or All Bids

- 37.1 The Purchaser reserves the right to accept or reject any Bid, and to annul the Bidding process and reject all Bids at any time prior to contract award, without thereby incurring any liability to the affected Bidder or Bidders or any obligation to inform the affected Bidder or Bidders.

### 38. Notification of Award

- 38.1 Prior to the expiration of the period of Bid validity, the Purchaser will notify the successful Bidder in writing by registered letter or by cable, to be confirmed in writing by registered letter or by cable, that its Bid has been accepted and on which basis the Bid has been accepted.
- 38.2 The notification of award will constitute the formation of the Contract.
- 38.3 Upon the successful Bidder's furnishing of the performance security pursuant to ITB Clause 40, the Purchaser will promptly notify the name of the winning Bidder to each unsuccessful Bidder and will discharge its Bid security, pursuant to Clause 20
- 38.4 The Contract will incorporate all Agreements between the Purchaser and successful Bidder.
- 38.5 If, after notification of award to the successful Bidder, an unsuccessful Bidder wishes to ascertain the grounds on which its Bid was not selected, it should address its request to the Purchaser within thirty (30) days of issue of the award notice. The Purchaser will promptly respond in writing to the unsuccessful Bidder.

### 39. Signing of Contract

- 39.1 At the time of notification of award, the Purchaser will send the successful Bidder the Contract Form provided in the Bidding Documents, incorporating all agreements between the parties.



## Section II – Instruction to bidders

39.2 Within fifteen (15) days of receipt of the letter informing the submission of performance guarantee and sign the contract, the successful Bidder shall sign and date the contract and return it to the purchaser

### 40. Performance Security

40.1 Within fifteen (15) days of the receipt of notification of award from the Purchaser, the successful Bidder shall furnish the performance security in accordance with the Special Conditions of Contract, in the Performance Security Form provided in the Bidding documents, or in another form acceptable to the Purchaser.

40.2 Failure of the successful Bidder to comply with the requirement of Sub - Clause 39.2 or Clause 40.1 shall constitute sufficient grounds for the annulment of the award and forfeiture of the Bid security, in which event the Purchaser may make the award to the next lowest evaluated Bidder or call for new Bids.

### 41. Corrupt or Fraudulent Practices

41.1 Government of Nepal requires that Purchaser, as well as Bidders observe the highest standard of ethics during the procurement and execution of such contracts. In pursuance of this policy, the Government of Nepal :

- a. Defines, for the purposes of this provision, the terms set forth below as follows:
  - i. "Corrupt practice" means the offering, giving, receiving or soliciting of any thing of value to influence the action of a public official in the procurement process or in contract execution; and
  - ii. "Fraudulent practice" means a misrepresentation of facts in order to influence a procurement process or the execution of a contract to the detriment of the GON, and includes collusive practice among bidders (prior to or after bid submission) designed to establish bid prices at artificial non-competitive levels and to deprive the borrower of the benefits of free and open competition;
- b. Will reject a proposal for award if it determines that the Bidder recommended for award has engaged in corrupt or fraudulent practices in competing for the contract in question;
- c. Will declare a firm ineligible for a stated period of time, to be awarded a NEA/ GON/Donor funded contract if it at any time determines that the firm has engaged in corrupt or fraudulent practices in competing for, or in executing, a NEA/ GoN/Donor funded contract.

41.2 Furthermore, Bidders shall be aware of the provision stated in clauses 5.4 and 24.1 of the GCC

### 42. Conduct of Bidders

42.1 The Bidder shall be responsible to fulfill his obligations as per the requirement of the Contract Agreement, Instruction to Bidders and GoN's Procurement Act and Regulations.

42.2 The Bidder shall not carry out or cause to carryout the following acts with an intention to influence the implementation of the procurement process or the procurement agreement:

- a. Give or propose improper inducement directly or indirectly,
- b. Distortion or misrepresentation of facts,
- c. Engaging in corrupt or fraudulent practice or involving in such act,
- d. Interference in participation of other competing bidders,
- e. Coercion or threatening directly or indirectly to cause harm to the person or the property of any person to be involved in the procurement proceedings,
- f. Collusive practice among bidders before or after submission of bids for distribution of works among bidders or fixing artificial/uncompetitive bid price with an intention to deprive the purchaser the benefit of open competitive bid price.
- g. Contacting the purchaser with an intention to influence the purchaser with regards to the bids or interference of any kind in examination and evaluation of the bids during the period from the time of opening of the bids until the notification of award of contract.

### 43. Blacklisting Bidders

43.1 Without prejudice to any other rights of the Purchaser under this Contract, the Public Procurement Monitoring Office (PPMO) may blacklist a Bidder for his conduct up to three years on the following grounds and seriousness of the act committed by the bidder:

- (a) If it is proved that the bidder committed acts contrary to the Sub - clause 42.2,
- (b) If the bidder fails to sign an agreement pursuant to clause 39
- (c) If it is proved later that the bidder has committed substantial defect in implementation of the contract or has not substantially fulfilled his obligations under the contract or the completed work is not of the specified quality as per the contract
- (d) If convicted by a court of law in a criminal offence which disqualifies the bidder from participating in the contract.



## Section II – Instruction to bidders

- (e) If it is proved that the contract agreement signed by the bidder was based on false or misrepresentation of bidder's qualification information,
- (f) acts mentioned in the Bidding Data or SCC

43.2 A Bidder declared blacklisted and ineligible by the GoN, Public procurement Office and or concerned Donor Agency in case of donor funded project shall be ineligible to bid for a contract during the period of time determined by the PPMO and or the concerned donor agency.



## Section III – Bidding Data Sheet

### SECTION III BIDDING DATA SHEET

The following specific data for the goods/services to be procured shall complement, supplement, or amend the provisions in the Instructions to Bidders (ITB). Whenever there is a conflict, the provisions herein shall prevail over those in ITB.

|         |   |
|---------|---|
| ITB 1.1 | Name of the Purchaser: <i>Nepal Electricity Authority</i><br><i>Medium Generation Operation and Maintenance Department, Trishuli HPS, Trishuli, Nuwakot, Nepal</i>  |
| ITB 2.1 | The Source of Fund: <i>Own Resources of Nepal Electricity Authority</i>   |
| ITB 2.1 | Invitation for Bid Number: <b>THPS-073/74-M/ST-12 RUNNER REPAIR WORKS FOR UNIT 3,5</b>  |
|         | <p>Bidder's Eligibility Requirements.</p> <p>3.1.1 In this Bid document, the words "Bidder, Joint Venture (JV), Goods" wherever have been used are as defined here under:</p> <ul style="list-style-type: none"><li>a. Bidder: "Bidder" shall mean a legally registered entity submitting the Bid Proposal. The entity may be a supplier or manufacturer of the tendered Goods/Service or contractor or any combination of them in the form of a joint venture.</li><li>b. Joint Venture (JV): "Joint Venture" shall mean a legally enforceable association constituted by legally registered entities with the purpose of committing the obligation required by the Bid.</li><li>c. Goods: "Goods" shall mean equipment, plant, goods, materials, etc, to be supplied and installed for the completion of the work as particularly described in the specifications.</li><li>d. The Bidder shall submit a notarized power of attorney authorizing the signatory of the Bid to commit the Bid on the behalf of the Bidder.</li></ul> <p>3.1.2 <u>Nepalese Bidder must fulfill the criteria as below:</u></p> <ul style="list-style-type: none"><li>a. The Bid must be signed &amp; stamped of company's seal properly.</li><li>b. A notarized copy of legal registration certificates shall be submitted along with the Bid. It must be clearly mentioned that the firm/company is permitted for the job, the Bid is invited.</li><li>c. The Bidder must submit notarized copy of VAT and PAN Registration Certificates</li><li>d. The Bidder must submit notarized copy of Tax Clearance Certificate or Submissions of Tax Returns up to F.Y.072/73</li><li>e. The manufacturer of the bidding products must be the holder of ISO 9001 or equivalent international standard certificate.</li><li>f. If the bidder is not the manufacturer of goods, he/she must produce manufacturer's letter of authorization (on manufacturing company's original letter head).</li></ul> |



### Section III – Bidding Data Sheet

- g. A written declaration made by the Bidder stating that the Bidder is not ineligible to participate in the Bid; has no conflict of interest in the proposed bid procurement proceedings and has not been punished for the profession or businesses related offence
- h. Manufacturer's Authorization Letter as asked in 18.1.a.1 of this section.
- i. Bidder shall duly fill the Technical Data Sheet in Section VII Technical Specification.
- j. Bidder shall submit the sufficient brochures/catalog/Product Data Sheet/drawings that justifies the data filled in Technical data sheet and GOODS are for intended use and similar to NEA requirement/ Installed GOODS at THPS Plant.
- k. The Bidder shall submit a notarized power of attorney authorizing the signatory of the Bid to commit the Bid on the behalf of the Bidder.
- l. When Bid is submitted by Joint Venture, it shall fulfill all the requirements as mentioned in Section II Instruction to Bidder (ITB) 7.1 along with as below:

Original of joint venture (JV) agreement legally binding on all JV partners shall be included in the Bid. The JV agreement shall bear the seal of the entities and signatures of the personnel authorized by the respective entities forming the JV. All such authorization documents shall also be included in the Bid. These authorization documents shall be on the original letterhead of the respective entity with stamp/seal of entity.

- i. The number of JV partners shall not exceed three (3).
- ii. The lead partner of the JV shall be a manufacturer or contractor legally registered for at least five (5) years.
- iii. The other partners of JV shall be manufacturers or contractors legally registered for at least three (3) years.
- iv. Notarized copies of legal registration certificates for each JV partners shall be submitted along with the Bid.

Other documents as needed to substantiate the Bid Proposal.

#### Foreign Bidder/ Nepalese bidder having foreign manufacturing authorization

Foreign Bidders not doing business in Nepal :

- a. For trans-border activities for any kinds of repair works whereby the part/components of THPS shall have to be transported across the boundary of Nepal, sufficient documentary evidence for the custom clearance/process (in and outside of Nepal) regarding the **Treaty of Trade, Treaty of Transit and Trade Related Agreements Between Government of Nepal and Neighboring Countries: Protocol to the Treaty of Trade** has to be submitted to the purchaser's satisfaction.
- b. Shall have to submit the documents to establish their legal status /registration in relevant country.
- c. Shall be represented by an agent in Nepal legally registered as per the relevant law of GoN.
- d. Other requirements regarding agent shall be as mentioned in 18.1.c.1 of this section.



### Section III – Bidding Data Sheet

|          |  |
|----------|--|
|          | <p>e. agent shall clearly be authorized for the service he shall perform on behalf of Bidder.</p> <p>f. other requirements are as mentioned above in 3.1.a, b, e, f (i to iii), g, h, I &amp; j.</p>                 |
| ITB 10.1 | <p>Purchaser's Name and Address:</p> <p>Nepal Electricity Authority</p> <p><i>Medium Generation Operation and Maintenance</i></p> <p><i>Trishuli HPS, Trishuli, Nuwakot, Nepal</i></p> <p>Tel. : +977-010-560099</p> |

|  |  |
|--|--|
| ITB 12.1   | The language of the bid is <a href="#">English</a>   |
| ITB 11.1 (b)   | <a href="#">In accordance with ITB 12 and ITB 14, the following schedules shall be submitted with the bid, including the priced Bill of Quantities for Unit Rate Contracts and Schedule of Prices for lump sum contracts.</a>  |
| Bid Price ITB 15.1   | i. The Bidder shall complete the price schedule in the format as given in Section VIII Sample form   |
| Bid Price ITB 15.2   | Delete Section II, ITB Clauses 15.2 (i), (ii) & (iii) completely and replace with following: <ul style="list-style-type: none"> <li>i. CIP plant site (Trishuli HPS, Trishuli, Nuwakot, Nepal) including all the duties &amp; taxes.</li> </ul>  |
| Currency of Bid ITB 16.1   | Delete Section II, ITB Clauses 16.1 completely and replace with following: The Prices shall be quoted in Nepalese Rupees.  |
| Documents Establishing the Bidder's Qualification to Perform the Contract ITB 18.1 | <p><a href="#">The Bidder's/Manufacturer's qualification criteria of section II ITB 18.1.a' b' c' d and e have been amended as below.</a></p> <ol style="list-style-type: none"> <li>1. <a href="#">Manufacturer's Authorization :-</a> <ol style="list-style-type: none"> <li>i. <a href="#">In the case of a Bidder offering to supply Goods/Service under the contract which the Bidder did not manufacture or otherwise produce, the Bidder shall be duly authorized solely by the Goods manufacturer or producer to supply the Goods in Nepal at Trishuli HPS, Trishuli, Nuwakot</a></li> <li>ii. <a href="#">The manufacturer's authorization certificate shall be submitted as asked in Technical Data sheet.</a></li> <li>iii. <a href="#">This certificate shall bear details of the Goods/Services that the manufacturer will be supplying under the authorization.</a></li> <li>iv. <a href="#">The authorization certificate shall be on the manufacturer's letterhead with seal/stamp of the manufacturer.</a></li> </ol> </li> <li>2. <a href="#">Financial Capability:- The Bidder must be financially sound, and it shall be evaluated as below:</a> <ol style="list-style-type: none"> <li>i. <a href="#">Financial statements: The Bidder including JV partners, if any, shall submit notarized copy of audited financial statements (Balance sheet and profit loss account) for the last three (3) fiscal years. Balance sheet and profit &amp; loss account sheet shall be signed &amp; sealed by the registered auditor(s).</a></li> <li>ii. <a href="#">Line of credit: In the event that working capital of the Bidder (Including each</a></li> </ol> </li> </ol> |



## Section III – Bidding Data Sheet

|  |  |
|--|--|
|  | <p>of JV partner in the case of JV) is to be supplemented with the line of credit from a bank, the Bidder shall submit original letter of bank pledging unequivocally that the bank will provide required financial support in case the Bidder is awarded the contract. The amount of line of credit shall be clearly mentioned in the bank letter. The Bid title and the Bid number shall also be mentioned in the bank letter.</p> <p>iii. Average annual turnover:</p> <p>(a) For the Bidder which is not in JV: The Bidder shall have average annual turnover (defined as the total payments received by the Bidder averaged over last three (3) years consecutive period) of not less than <b>NRs.15 Lakhs</b></p> <p>(b) For the JV Bidder: The average annual turnover of the lead partner shall not be less than 40% of the amount stated above in 2.iii.a. The average annual turnover of other partners shall not be less than 25% of the amount stated in 2.iii.a. Aggregate annual turnover (with line of credit facilities) of all the JV partners shall not be less than the values specified above in 2.iii.a. i</p> <p>iv. Availability of financial resources (Working Capital):</p> <p>(a) For the Bidder which is not a joint venture: The Bidder shall have working capital (defined as total current assets less total current liabilities) of at least <b>NRs. 10 Lakhs</b> in last fiscal year</p> <p>If the Bidder's working capital is inadequate, the Bidder shall supplement working capital with Banker's letter confirming the availability of a line of credit such that aggregate of the Bidder's working capital for last fiscal year and the line of credit shall not be less than the required amount.</p> <p>(b) For the JV Bidder: Working capital of lead partner shall not be less than 40% of the amount stated above in (2.iv.a). Working capital of other partners shall not be less than 25% of the amount stated in (2.iv.a). Aggregate working capital (with line of credit facilities) of all the JV partners shall not be less than the values specified in (2.iv.a).</p> <p><b>Manufacturing experience</b></p> <p>i. The Bidder shall submit at least two numbers of end user certificates showing that the manufacturer has successfully completed the supply of the Goods of same quantity as a main supplier over last five (5) years period ending on the last date of Bid submission.</p> <p>ii. The end user certificates shall be on the letterhead of the end user with valid address for correspondence and signed by or on behalf of the end user.</p> <p>iii. If the Bidder has proposed same spare (from same manufacturer and model) as those are installed/Used in this plant then this certificate is not necessary for those items.</p> <p>iv. ISO certificate: Bidder must submit the manufacturer's valid quality ISO or equivalent international standard certificate as asked in Technical data sheet.</p> <p>3. In the case of a Bidder not doing business within Nepal, the Bidder shall be represented by an agent in Nepal, who shall be capable to fulfill the contractual obligation. This shall be substantiate by a letter of experience in similar nature of job at least once in past.</p> <p>4. Substantiate with Technical specification :</p> |
|--|--|

### Section III – Bidding Data Sheet

|                       |  |
|-----------------------|--|
|                       | <p>i. The offered GOODS/Services shall be in conformity with the technical specifications.</p> <p>ii. The Bidder must fill the technical data sheet provided in section VII technical specification of bidding document.</p> <p>iii. In order to prove that the Goods/Services offered are of acceptable quality and standard and in conformity with the technical specifications, the Bidder must furnish the documentary evidence in the form of brochures, product data sheet, drawings and detailed description of goods with test reports as justified. The brochures/ product data sheet /drawings/ test reports must be sufficient to justify the data filled in technical data sheet.</p> <p>Others:</p> <p>(i) Litigation history:- The Bidder including all JV partners, if any, shall submit all claims, arbitration or other litigation pending or already resolved from the contracts executed or currently under execution.</p> <p>(ii) An agent can submit bids on behalf of more than one manufacturer but separate complete bids including bid security shall be submitted for each manufacturer.</p> <p>(iii) If an Agent submits bids on behalf of more than one Manufacturer, unless each such bid is accompanied by a separate Bid Form for each bid, and a bid security.</p> |
| Bid security ITB 20.1 | Amount of Bid security: not less than <b>NRs 80,000.00</b> . The validity period shall be 30 days beyond Bid validity period   |
| ITB 20.2              | <p>a. The Bid Security shall be in the currency of Bid.</p> <p>b. It shall be in the form of earnest acceptable to the purchaser, bank draft drawn in favor of purchaser or a bank guarantee from any reputed bank in Nepal</p> <p>c. If it has been issued from foreign bank, which must be endorsed/counter guaranteed by a reputed bank in Nepal.</p> <p>d. The Bid security must specifically be mentioned to be applicable to the offer of the Bidder.</p> <p>e. If the Bid security is submitted by someone other than the Bidder, it must clearly be mentioned that the "Bid Bond is submitted on behalf of the Bidder" in the Bid Bond itself.</p> <p>f. The Bid Bond must be issued in the name of JV, when Bid is submitted in joint venture.</p> <p>g. The validity period of the Bid Bond shall be 30 (Thirty) days beyond the Bid validity period.</p>  |
| ITB 21.1              | Bid validity period: 90 calendar days from the date of Bid closing day.  |
| ITB 22.1              | The Bidder shall prepare and submit only one volume, no copy is required   |
| ITB 23.2 (a)          | <p>Address for Bid submission:</p> <p>Trishuli Hydropower Station, Trishuli, Nuwakot</p> <p>Tel. : + 977 (01) <b>560099</b></p>  |

### Section III – Bidding Data Sheet

|  |  |
|--|--|
|  | Fax : + 977 (01) <b>560099</b>   |
| ITB 23.2 (b)   | <i>IFB title and number: : THPS-073/74-M/ST-12 (RUNNER REPAIR WORKS FOR UNIT 3,5)</i>  |
| ITB 24.1   | <p><i>Deadline for bid submission :</i></p> <p><i>Date : 23 March, 2017 Time : 12:00 hrs</i></p> <p><i>Place : Trishuli Hydropower Station, Trishuli, Nuwakot</i></p> <p><b>Tel: 977-010-560099</b></p>  |
| ITB 27.1   | <p>Bid Opening : Date : 23 March, 2017 Time : 14:00 hrs</p> <p>Place : Trishuli Hydropower Station, Trishuli, Nuwakot</p> <p><b>Tel: 977-010-560099</b></p>  |
| Examination of Bids and Determination of Responsiveness ITB 29.1 | <p>Prior to the evaluation of Bids, it shall be examined for responsiveness on the basis as mentioned below. The Bid of a Bidder shall be rejected as being nonresponsive if,</p> <ul style="list-style-type: none"> <li>(a) The Bid is not signed by an authorized signatory.</li> <li>(b) <i>The Bid has not stamped with company seal.</i></li> <li>(c) <i>The Bid submitted is not the same/original as either issued or down loaded from NEA's web site <a href="http://www.e-nea.org.np">http://www.e-nea.org.np</a></i></li> <li>(d) <i>The Bid is downloaded from NEA's web site but submitted without the bank voucher as mentioned in invitation of Bid.</i></li> <li>(e) <i>The Bid document is purchased in the name of one firm and submitted by another firm. The name of the Bidder must be mentioned in the bank voucher.</i></li> <li>(f) <i>If it is proved that the Bidders have submitted the Bid by making such an arrangement which limits the participation of other Bidders and also influence the Bid price in any manner.</i></li> <li>(g) <i>The Bid is received after the dead line for submission of Bid.</i></li> <li>(h) <i>The Bid is conditional.</i></li> <li>(i) <i>The required documents are not submitted authenticated English version.</i></li> <li>(j) <i>The Bidder has not offered all the items and quantity as mentioned in price schedule.</i></li> <li>(k) <i>The Bid has price escalation clause.</i></li> <li>(l) <i>The Bid does not meet all the eligibility criteria as mentioned in clause 3.1 of this section.</i></li> <li>(m) <i>The Bid does not meet all the qualification criteria as mentioned in clause 18.1 of this section.</i></li> <li>(n) <i>The description provided by the Bidder pertaining to the qualification is found to be false or is substantially incomplete.</i></li> <li>(o) <i>The technical information and the documents required to justify the goods for in compliance with the specification are not submitted or are not sufficient.</i></li> <li>(p) <i>The TECHNICAL DATA SHEET in section VII (technical specification) of Bid</i></li> </ul> |

### Section III – Bidding Data Sheet

|  |   |
|--|---|
|  | <p>document is not filled and sufficient documents (broachers/ technical data sheet/ drawings etc) required to justify the filled data are not submitted.</p> <p>(q) The offered Goods are not substantially in compliance with the specification.</p> <p>(r) The Bid does not meets all the requirements regarding Bid Security as mentioned in clause 20.1 and 20.2 of this section.</p> <p>(s) The offered delivery schedule is more than as in schedule of requirement</p> <p>(t) The Data on qualifications of Bidder/Manufacturer (firm G) are not filled</p> <p>(u) The firms G are filled but supporting documents required are not furnished or they are false.</p> <p>(v) Any conditions mentioned in the tender document are not fulfilled.</p> <p>(w) The Bid fails to satisfy that the Bid is fully cognizant of the scope of work</p> <p>(x) The Bidder or even a partner in JV is blacklisted in its contractual obligations in the past NEA, GON, PPO and or concerned donor agency.</p> <p>(y) The Bid is downloaded from NEA's web site but not electronically submitted as instructed in this Section of "Special Instruction to Bidders for e-Bidding".</p> |
|--|---|

|           |  |
|-----------|--|
| ITB 31.1  | Purchaser will evaluate & compare the Bid amount of only those Bids which have been determined to be substantially responsive on the basis as mentioned in clause No. 29.1 of this section.  |
| ITB 31.4  | Not Applicable   |
| ITB 31.5. | Alternative Bids: Not applicable   |
| ITB 31.6  | 31.1.a, b, c, d, e, f & g have been replaced with as below: i. Applicable delivery schedule shall be as specified in schedule of requirement.  |
| ITB 32.0. | Domestic preference:- as per the rules and regulation of GON.  |
| ITB 34.3  | To show the technical and production capability of a Bidder, the Bidder must submit the documents as sought in clause 18.1.b.2.  |
| ITB 34.4  | An affirmative determination will be prerequisite for the award of the contract to the Bidder and negative determination will result in rejection the Bidder's Bid. Such a determination shall be based on the criteria as mentioned in clause No. 29.1 of this section. |
| ITB 36.1  | Percentage for quantity increase/decrease: up to 15 %  |
| ITB 37    | The clause is modified as follows:   |
| ITB 37.1  | Not applicable   |
| ITB 37.2  | In awarding the contract for the Goods/Services, NEA also reserves the right to make the award to one bidder for all or part of the goods to more bidders.   |

## Section III – Bidding Data Sheet

### G. Special Instruction to Bidders for e-Bidding

- A) Bid submission procedures through electronically (e-submission) only:
- i. Interested eligible bidders shall, either purchase the hard copy of the bidding document directly from the Employer's office as specified in the Invitation for Bid (IFB) or may download the necessary parts of the bidding documents from e-procurement section in NEA's web site <http://www.e-nea.org.np>. In case, the bidders choose to download the bidding documents, prepare the bids on downloaded documents, and submit their bids electronically. The Bidders shall be required to deposit the non refundable fee for the bidding document (as specified in the bid notice) in the bank account specified in the IFB and electronic scanned copy (\*.pdf format) of the bank deposit voucher shall also be submitted along with the electronic bid files.
  - ii. The Bidder shall fill the following documents and forms (in hard copy of issued bid documents), signed by the authorized representative with seal of the company.
    - a) Bill of Quantity (BOQ) with rate, amount, b) Forms of Bid, Qualification Information

The Bidder shall then scan the completed original documents, forms in PDF formats with appropriate filename shown in the table below.

| S.No. | Document                               | PDF file name     | Requirement                  | Remarks                 |
|-------|--|-------------------|------------------------------|-------------------------|
| 1     | Form of Bid                            | Bid form -1       | Mandatory                    |                         |
| 2     | Bid Security (Bank Guarantee)          | Bid security-2    | Mandatory                    |                         |
| 3     | Company registration,                  | Company reg-3     | Mandatory                    | All firms in case of JV |
| 4     | VAT/PAN registration,                  | VAT reg-4         | Mandatory for National firms | All firms in case of JV |
| 5     | Tax clearances certificate,            | Tax-5             | Mandatory for National firms | All firms in case of JV |
| 6     | Power of Attorney of Bid signatory     | Power of Att-6    | Mandatory                    |                         |
| 7     | Joint venture agreement                | JV doc-7          | Mandatory                    | In case of JV           |
| 8     | Qualification Information              | Qualification-8   | Mandatory                    |                         |
| 9     | BOQ with rate, amount and total amount | BOQ-9             | Mandatory                    |                         |
| 10    | Manufacturers Authorization            | Authorization-10  | Mandatory                    |                         |
| 11    | Technical Data Sheet                   | TDS-11            | Mandatory                    |                         |
| 12    | Certification Documents                | Certifications-12 | Mandatory                    |                         |
| 13    | Declaration Form                       | Declaration-13    | Mandatory                    |                         |

Note: Mandatory means the mentioned files shall be included in e-submission and non-submission of such file shall be considered as non-responsive bid.

- iii. For e-submission purpose the Bidder shall, at first, register in the e-procurement section NEA's web site <http://www.e-nea.org.np>
- iv. After preparing all the required bidding documents in PDF, scan the files as specified in (ii).



### Section III – Bidding Data Sheet

- v. The Bidder shall upload the PDF bid files and submit the complete bid online through e-procurement section of NEA's website <http://www.e-nea.org.np> within the specified date and time.
  - vi. The e-procurement system will accept the e-submission of bid from the date after publishing of notice and will automatically disallow the e-submission of bid after the deadline for submission of bid, as specified above.
  - vii. The standard time for e-submission is Nepalese Standard Time as set out in the server of IT Department of NEA.
  - viii. When a bidder submits his bid in hard copy, the e-procurement section does not allow the bidder to submit his Substitution or Modification or Withdrawal through e-procurement section of NEA's web site.
  - ix. Bidders may submit his Substitution or Modification or Withdrawal either in hard copy or through e-submission.
  - x. For Substitution of Bid, the Bidder shall follow similar steps as specified in **ITB Clause -24 with a Substitution letter in PDF file.**
  - xi. For Modification or Withdrawal of bid, the Bidder is required to submit PDF scan copy of their Modification or Withdrawal letter and a written Power of Attorney of the signatory for Modification/Withdrawal, duly signed by Authorized Representative/s of the Firm / all authorized Joint Venture partners.
  - xii. When a Bidder submits electronic bid by downloading the bidding documents from the NEA's webpage it is assumed that the Bidder prepares his bid by studying and examining all the Bidding documents including specifications and conditions of contract.
  - xiii. In case the Bidder choose to download the bidding documents and deposit the cost of bidding documents (as specified in the bid notice), such deposited amount shall be verified by the office during bid evaluation process. **The bid shall be considered as non-responsive and shall not be evaluated if the specified cost for bidding document is not deposited in the Employer's Revenue account.**
  - xiv. Proposed facility for submission of bid electronically through e-submission is to increase transparency, non-discrimination, equality of access, and open competition. The Bidders shall be fully responsible to use the e-submission facility in e-procurement section of NEA's website <http://www.e-nea.org.np> in specified procedures and in no case the Employer shall be held liable for Bidder's inability to use this facility.
- B) Requirements and Conditions for e-submission of bid:
- i. The Bidder shall submit his bid electronically in PDF files in the manner as specified above, original hard copy shall be submitted within three days when asked by employer.
  - ii. In case, if both the electronic bid and original bid in hard copy are submitted to the Employer within the bid submission deadline, the Bidder's electronic bid and original bid in hard copy will be accepted for evaluation provided the facts and figures in hard copy confirm to the PDF files in electronic bid. If there is any discrepancy in fact and figures between the electronic bid and original bid in hard copy, it will be treated as two separate bids from one Bidder and hence, both the electronic bid and original bid in hard copy shall be disqualified.
  - iii. However, for electronically submitted bid in PDF files, the Bidder shall be required to submit documents/clarifications for verification purpose upon notification to do so from the Employer **within 3 days.**
  - iv. The e-submitted bids must be readable through open standards interfaces. Unreadable and or partially submitted bid files (not complying with the ITB Clauses) shall be considered incomplete and rejected for further bid evaluation.
  - v. In addition to electronically submitted PDF files, the Bidder shall be required to submit documents and clarifications as required by the Employer. Non-submission of such documents and or clarifications by the Bidder within specified time may cause forfeiture of Bid Security.



### Section III – Bidding Data Sheet

- vi. In case of major discrepancy found between electronically submitted PDF bid files and documents/clarifications provided by the Bidder, the bid shall not be considered for further evaluation.
  - vii. The Bidder shall attach the Bid Security Guarantee in the format attached in the Bid Document. The Bid Security may be forfeited
    - a. if the Bidder does not respond to and/or submit the documents and or clarifications when requested by the Employer.
    - b. if major discrepancy is found between e-submitted bid information and documents/clarifications provided by the Bidder during verification process as requested by the Employer.
- C) Bid Opening process for e-submitted bid
- i. Electronically submitted bid shall be opened first at the Bid opening time.
  - ii. The e-procurement system allows the Employer to download and open the e-submitted bid files from the bidders only after the time for opening the bids.
  - iii. The e-submitted bids must be readable through open standards interfaces. Unreadable and or partially submitted bid files (not complying with the ITB Clauses) shall be considered incomplete and rejected for further bid evaluation.
  - iv. After opening of e-submitted bids files, all files shall be printed and recorded at the time of bid opening.
- b) In case of "WITDRAWAL" or "MODIFICATION" or "SUBSTITUTION" by the Bidder through e-submission, the e-submitted PDF files under "WITDRAWAL" or "MODIFICATION" or "SUBSTITUTION" shall be opened and read out first. Bids for which acceptable notice of "WITDRAWAL" or "SUBSTITUTION" has been submitted pursuant to ITB Clause shall not be opened.
- D) Bid Evaluation and Comparison process for e-submitted bid
- i. In case of e-submitted bids, the Employer evaluates the bid based on the information as per electronically submitted bid files. For clarification/ verification purpose, the Employer may request the Bidder to submit documents/ clarifications.
  - ii. In case, the Bidder could not substantiate or provide evidence to prove the information provided in e-submitted bid through documents/clarifications, the bid shall not be considered for further evaluation and respective ITB Clause for forfeiture of bid security shall be applicable.
  - iii. The e-submitted bids must be readable through open standards interfaces. Unreadable and or partially submitted bid files (not complying with the ITB Clauses) shall be considered incomplete and rejected for further bid evaluation.
- E) Qualification Information
- In case of e-Bidding, the Bidder is required to submit the documents to prove minimum qualification requirements only and not the detail documents.
- F) Bid Security Format
- Form of Bid security shall include the provision as 'This Bank Guarantee shall not be withdrawn or released merely upon return of the original Guarantee by the Bidder unless notified by the Employer for the release of the Guarantee'.



## SECTION IV GENERAL CONDITIONS OF CONTRACT

### A. General

#### 1. Definitions

1.1 In this Contract, the following terms shall be interpreted as indicated:

- (a) "The Contract" means the agreement entered into between the Purchaser and the Bidder, as recorded in the Contract Form signed by the parties, including all attachments and appendices thereto and all documents incorporated by reference therein.
- (b) "Contract Documents" means the documents listed in the Agreement, including amendments thereto. Subject to the order of precedence set forth in the Agreement, all documents forming the Contract (and all parts thereof) are intended to be correlative, complementary and mutually explanatory.
- (c) "The Contract Price" means the price payable to the Bidder under the Contract for the full and proper performance of its contractual obligations.
- (d) "The Goods" means all of the equipment, machinery, and/or other materials which the Bidder is required to supply to the Purchaser under the Contract
- (e) "The Services" means those services ancillary to the supply of the Goods, such as transportation and insurance, and any other incidental services, such as installation, commissioning, provision of technical assistance, training, and other such obligations of the Bidder covered under the Contract
- (f) Delivery means the transfer of the Goods from the Bidder to the Purchaser in accordance with the terms and conditions set forth in the contract
- (g) "Completion" means the fulfillment of the related services by the Bidder in accordance with the terms and conditions set forth in the contract
- (h) "Purchaser Country" is the country specified in the Special Conditions of Contract (SCC)
- (i) "GCC" means the General Conditions of Contract contained in this section
- (j) "SCC" means the Special Conditions of Contract
- (k) "The Purchaser" means the organization purchasing the Goods, as named in SCC
- (l) "The Bidder" means the individual or firm supplying the Goods and Services under this Contract and named in SCC
- (m) "The Project Site," where applicable, means the place or places named in SCC
- (n) "Day" means calendar day
- (o) "The Governing Language" of the contract shall be English/Nepali.

## Section IV – General Condition of Contract

- 2. Application** 2.1 These General Conditions shall apply to the extent that they are not superseded by provisions of other parts of the Contract.
- 3. Country of Origin** 3.1 All Goods and Services supplied under the Contract shall have their origin in Nepal or in the countries and territories eligible under the rules of the Donor Agency, as further elaborated in the SCC
- 3.2 For purposes of this Clause, “origin” means the place where the Goods were mined, grown, or produced, or from which the Services are supplied. Goods are produced when, through manufacturing, processing, or substantial and major assembly of components, a commercially recognized new product results that is substantially different in basic characteristics or in purpose or utility from its components.
- 3.3 The origin of Goods and Services is distinct from the nationality of the Bidder.
- 4. Standards** 4.1 The Goods supplied under this Contract shall conform to the standards mentioned in the Technical Specifications, and, when no applicable standard is mentioned, to the authoritative standards appropriate to the Goods’ country of origin. Such standards shall be the latest issued by the concerned institution.
- 4.2 Wherever reference is made in the Technical Specifications to specific standards and codes to be met by the goods and materials to be furnished or tested, the provisions of the latest current edition or revision of the relevant shall apply, unless otherwise expressly stated in the Contract. Where such standards and codes are national or relate to a particular country or region, other authoritative standards that ensure substantial equivalence to the standards and codes specified will be acceptable.
- 5. Use of Contract Documents and Information; Inspection and Audit by the Donor Agency** 5.1 The Bidder shall not, without the Purchaser’s prior written consent, disclose the Contract, or any provision thereof, or any specification, plan, drawing, pattern, sample, or information furnished by or on behalf of the Purchaser in connection therewith, to any person other than a person employed by the Bidder in the performance of the Contract. Disclosure to any such employed person shall be made in confidence and shall extend only so far as may be necessary for purposes of such performance.
- 5.2 The Bidder shall not, without the Purchaser’s prior written consent, make use of any document or information enumerated in GCC Clause 5.1 except for purposes of performing the Contract.
- 5.3 Any document, other than the Contract itself, enumerated in GCC Clause 5.1 shall remain the property of the Purchaser and shall be returned (all copies) to the Purchaser on completion of the Bidder’s performance under the Contract if so required by the Purchaser.
- 5.4 The Bidder shall permit the GoN/Donor Agency to inspect the Bidder’s accounts and records relating to the performance of the Bidder and to have them audited by auditors appointed by the GoN/Donor Agency, if

## Section IV – General Condition of Contract

so required by the GoN/Donor Agency.

- 6. Patent Rights**
- 6.1 The Bidder shall indemnify the Purchaser against all third-party claims of infringement of patent, trademark, or industrial design rights arising from use of the Goods or any part thereof in Nepal.
- 7. Performance Security**
- 7.1 Within thirty (30) days of receipt of the notification of Contract award, the successful Bidder shall furnish to the Purchaser the performance security in the amount specified in SCC.
- 7.2 The proceeds of the performance security shall be payable to the Purchaser as compensation for any loss resulting from the Bidder's failure to complete its obligations under the Contract.
- 7.3 The performance security shall be denominated in the currency of the Contract, or in a freely convertible currency acceptable to the Purchaser and shall be in one of the following forms:
- a bank guarantee or an irrevocable letter of credit issued by a reputable bank located in Nepal or abroad, acceptable to the Purchaser, in the form provided in the Bidding documents or another form acceptable to the Purchaser; or
  - a cashier's or certified check recognized as good for payment.
- 7.4 The performance security will be discharged by the Purchaser and returned to the Bidder not later than thirty eight (30) days following the date of completion of the Bidder's performance obligations under the Contract, including any warranty obligations, unless otherwise specified in SCC. 8.
- 8. Inspections and Tests**
- 8.1 The Purchaser or its representative shall have the right to inspect and/or to test the Goods to confirm their conformity to the Contract specifications at no extra cost to the Purchaser. SCC and the Technical Specifications shall specify what inspections and tests the Purchaser requires and where they are to be conducted. The Purchaser shall notify the Bidder in writing, in a timely manner, of the identity of any representatives retained for these purposes.
- 8.2 The inspections and tests may be conducted on the premises of the Bidder or its subcontractor(s), at point of delivery, and/or at the Goods' final destination. If conducted on the premises of the Bidder or its subcontractor(s), all reasonable facilities and assistance, including access to drawings and production data, shall be furnished to the inspectors at no charge to the Purchaser.
- 8.3 Should any inspected or tested Goods fail to conform to the Specifications, the Purchaser may reject the Goods, and the Bidder shall either replace the rejected Goods or make alterations necessary to meet specification requirements free of cost to the Purchaser.
- 8.4 The Purchaser's right to inspect, test and, where necessary, reject the Goods after the Goods' arrival in Nepal shall in no way be limited or waived by reason of the Goods having previously been inspected, tested, and passed by the Purchaser or its representative prior to the Goods' shipment from the country of origin.
- 8.5 Nothing in GCC Clause 8 shall in any way release the Bidder from any warranty or other obligations under this Contract. 9

## Section IV – General Condition of Contract

- 9. Packing**
- 9.1 The Bidder shall provide such packing of the Goods as is required to prevent their damage or deterioration during transit to their final destination, as indicated in the Contract. The packing shall be sufficient to withstand, without limitation, rough handling during transit and exposure to extreme temperatures, salt and precipitation during transit, and open storage. Packing case size and weights shall take into consideration, where appropriate, the remoteness of the Goods' final destination and the absence of heavy handling facilities at all points in transit.
- 9.2 The packing, marking, and documentation within and outside the packages shall comply strictly with such special requirements as shall be expressly provided for in the Contract, including additional requirements, if any, specified in SCC, and in any subsequent instructions ordered by the Purchaser.
- 10. Delivery and Documents**
- 10.1 Delivery of the Goods shall be made by the Bidder in accordance with the terms specified in the Schedule of Requirements. The details of shipping and/or other documents to be furnished by the Bidder are specified in SCC.
- 10.2 For purposes of the Contract, "EXW," "FOB," "CIF," "CIP," and other trade terms used to describe the obligations of the parties shall have the meanings assigned to them by the current edition of Inciters published by the International Chamber of Commerce, Paris.
- 10.3 Documents to be submitted by the Bidder are specified in SCC.
- 11. Insurance**
- 11.1 The Goods supplied under the Contract shall be fully insured in a freely convertible currency against loss or damage incidental to manufacture or acquisition, transportation, storage, and delivery in the manner specified in the SCC.
- 11.2 Where delivery of the Goods is required by the Purchaser on a CIF or CIP basis, the Bidder shall arrange and pay for cargo insurance, naming the Purchaser as beneficiary. Where delivery is on a FOB or FCA basis, insurance shall be the responsibility of the Purchaser.
- 12. Transportation**
- 12.1 Where the Bidder is required under Contract to deliver the Goods FOB, transport of the Goods, up to and including the point of putting the Goods on board the vessel at the specified port of loading, shall be arranged and paid for by the Bidder, and the cost thereof shall be included in the Contract Price. Where the Bidder is required under the Contract to deliver the Goods FCA, transport of the Goods and delivery into the custody of the carrier at the place named by the Purchaser or other agreed point shall be arranged and paid for by the Bidder, and the cost thereof shall be included in the Contract Price.
- 12.2 Where the Bidder is required under Contract to deliver the Goods CIF or CIP, transport of the Goods to the port of destination or such other named place of destination in Nepal, as shall be specified in the Contract, shall be arranged and paid for by the Bidder, and the cost thereof shall be included in the Contract Price.
- 12.3 Where the Bidder is required under the Contract to transport the Goods to a specified place of destination within Nepal, defined as the Project

## Section IV – General Condition of Contract

Site, transport to such place of destination in Nepal, including insurance and storage, as shall be specified in the Contract, shall be arranged by the Bidder, and related costs shall be included in the Contract Price.

12.4 Where the Bidder is required under Contract to deliver the Goods CIF or CIP, no restriction shall be placed on the choice of carrier. Where the Bidder is required under Contract (a) to deliver the Goods FOB or FCA, and (b) to arrange on behalf and at the expense of the Purchaser for international transportation on specified carriers or on national flag carriers of Nepal, the Bidder may arrange for such transportation on alternative carriers if the specified or national flag carriers are not available to transport the Goods within the period(s) specified in the Contract

### 13. Incidental Services

13.1 The Bidder may be required to provide any or all of the following services, including additional services, if any, specified in SCC:

- (a) performance or supervision of on-site assembly and/or start-up of the supplied Goods
- (b) furnishing of tools required for assembly and/or maintenance of the supplied Goods
- (c) furnishing of a detailed operations and maintenance manual for each appropriate unit of the supplied Goods
- (d) performance or supervision or maintenance and/or repair of the supplied Goods, for a period of time agreed by the parties, provided that this service shall not relieve the Bidder of any warranty obligations under this Contract; and
- (e) training of the Purchaser's personnel, at the Bidder's plant and/or onsite, in assembly, start-up, operation, maintenance, and/or repair of the supplied Goods

13.2 Prices charged by the Bidder for incidental services, if not included in the Contract Price for the Goods, shall be agreed upon in advance by the parties and shall not exceed the prevailing rates charged to other parties by the Bidder for similar services.

### 14. Spare Parts

14.1 As specified in SCC, the Bidder may be required to provide any or all of the following materials, notifications, and information pertaining to spare parts manufactured or distributed by the Bidder:

- (a) such spare parts as the Purchaser may elect to purchase from the Bidder, provided that this election shall not relieve the Bidder of any warranty obligations under the Contract; and
- (b) in the event of termination of production of the spare parts:
  - (i) advance notification to the Purchaser of the pending termination, in sufficient time to permit the Purchaser to procure needed requirements; and
  - (ii) following such termination, furnishing at no cost to the Purchaser, the blueprints, drawings, and specifications of the spare parts, if requested.



## Section IV – General Condition of Contract

### 15. Warranty

- 15.1 The Bidder warrants that the Goods supplied under the Contract are new, unused, of the most recent or current models, and that they incorporate all recent improvements in design and materials unless provided otherwise in the Contract. The Bidder further warrants that all Goods supplied under this Contract shall have no defect, arising from design, materials, or workmanship (except when the design and/or material is required by the Purchaser's specifications) or from any act or omission of the Bidder, that may develop under normal use of the supplied Goods in the conditions prevailing in the country of final destination.
- 15.2 This warranty shall remain valid for **twelve (12) months** after the Goods, or any portion thereof as the case may be, have been delivered to and accepted at the final destination indicated in the Contract, or for eighteen (18) months after the date of shipment from the port or place of loading in the source country, whichever period concludes earlier, unless specified otherwise in SCC.
- 15.3 The Purchaser shall promptly notify the Bidder in writing of any claims arising under this warranty.
- 15.4 Upon receipt of such notice, the Bidder shall, within the period specified in SCC and with all reasonable speed, repair or replace the defective Goods or parts thereof, without costs to the Purchaser other than, where applicable, the cost of inland delivery of the repaired or replaced Goods or parts from EXW or the port or place of entry to the final destination.
- 15.5 If the Bidder, having been notified, fails to remedy the defect(s) within the period specified in SCC, the Purchaser may proceed to take such remedial action as may be necessary, at the Bidder's risk and expense and without prejudice to any other rights which the Purchaser may have against the Bidder under the Contract.

### 16. Payment

- 16.1 The method and conditions of payment to be made to the Bidder under this Contract shall be specified in SCC.
- 16.2 The Bidder's request(s) for payment shall be made to the Purchaser in writing, accompanied by an invoice describing, as appropriate, the Goods delivered and Services performed, and by documents submitted pursuant to GCC Clause 10, and upon fulfillment of other obligations stipulated in the Contract.
- 16.3 Payments shall be made promptly by the Purchaser, but in no case later than thirty (30) days after approval of the invoice by the Purchaser.
- 16.4 The currency or currencies in which payment is made to the Bidder under this Contract shall be specified in SCC subject to the following general principle: payment will be made in the currency or currencies in which the payment has been requested in the Bidder's Bid.
- 16.5 All payments shall be made in the currency or currencies specified in the SCC pursuant to GCC 16.4.

### 17. Prices

- 17.1 Prices charged by the Bidder for Goods delivered and Services performed under the Contract shall not vary from the prices quoted by the Bidder in its Bid, with the exception of any price adjustments authorized in SCC or in the Purchaser's request for Bid validity



## Section IV – General Condition of Contract

extension, as the case may be.

- 18. Change Orders**
- 18.1 The Purchaser may at any time, by a written order given to the Bidder pursuant to GCC Clause 32, make changes within the general scope of the Contract in any one or more of the following:
- drawings, designs, or specifications, where Goods to be furnished under the Contract are to be specifically manufactured for the Purchaser;
  - the method of shipment or packing;
  - the place of delivery; and/or
  - the Services to be provided by the Bidder.
- 18.2 If any such change causes an increase or decrease in the cost of, or the time required for, the Bidder's performance of any provisions under the Contract, an equitable adjustment shall be made in the Contract Price or delivery schedule, or both, and the Contract shall accordingly be amended. Any claims by the Bidder for adjustment under this clause must be asserted within twenty eight (28) days from the date of the Bidder's receipt of the Purchaser's change order.
- 19. Contract Amendments**
- 19.1 Subject to GCC Clause 18, no variation in or modification of the terms of the Contract shall be made except by written amendment signed by the parties.
- 20. Assignment**
- 20.1 The Bidder shall not assign, in whole or in part, its obligations to perform under this Contract, except with the Purchaser's prior written consent.
- 21. Subcontracts**
- 21.1 The Bidder shall notify the Purchaser in writing of all subcontracts awarded under this Contract if not already specified in the Bid. Such notification, in the original Bid or later, shall not relieve the Bidder from any liability or obligation under the Contract.
- 21.2 Subcontracts must comply with the provisions of GCC Clause 3.
- 22. Delays in the Bidder's Performance**
- 22.1 Delivery of the Goods and performance of Services shall be made by the Bidder in accordance with the time schedule prescribed by the Purchaser in the Schedule of Requirements.
- 22.2 If at any time during performance of the Contract, the Bidder or its subcontractor(s) should encounter conditions impeding timely delivery of the Goods and performance of Services, the Bidder shall promptly notify the Purchaser in writing of the fact of the delay, its likely duration and its cause(s). As soon as practicable after receipt of the Bidder's notice, the Purchaser shall evaluate the situation and may at its discretion extend the Bidder's time for performance, with or without liquidated damages, in which case the extension shall be ratified by the parties by amendment of Contract.
- 22.3 Except as provided under GCC Clause 25, a delay by the Bidder in the performance of its delivery obligations shall render the Bidder liable to the imposition of liquidated damages pursuant to GCC Clause 23, unless an extension of time is agreed upon pursuant to GCC Clause 22.2 without the application of liquidated damages.



## Section IV – General Condition of Contract

### 23. Liquidated Damages

23.1 Subject to GCC Clause 25, if the Bidder fails to deliver any or all of the Goods or to perform the Services within the period(s) specified in the Contract, the Purchaser shall, without prejudice to its other remedies under the Contract, deduct from the Contract Price, as liquidated damages, a sum equivalent to the percentage specified in SCC of the delivered price of the delayed Goods or unperformed Services for each week or part thereof of delay until actual delivery or performance, up to a maximum deduction of the percentage specified in SCC. Once the maximum is reached, the Purchaser may consider termination of the Contract pursuant to Clause 24.

### 24. Termination for Default

24.1 The Purchaser, without prejudice to any other remedy for breach of Contract, by written notice of default sent to the Bidder, may terminate this Contract in whole or in part:

- a. if the Bidder fails to deliver any or all of the Goods within the period(s) specified in the Contract, or within any extension thereof granted by the Purchaser pursuant to Clause 22; or
- b. if the Bidder fails to perform any other obligation(s) under the Contract.
- c. if the Bidder, in the judgment of the Purchaser, has engaged in corrupt or fraudulent practices in competing for or in executing the Contract. For the purpose of this clause: “corrupt practice” means the offering, giving, receiving, or soliciting of anything of value to influence the action of a public official in the procurement process or in contract execution. “fraudulent practice” means a misrepresentation of facts in order to influence a procurement process or the execution of a contract to the detriment of the Purchaser, and includes collusive practice among Bidders (prior to or after Bid submission) designed to establish Bid prices at artificial non-competitive levels and to deprive the Purchaser of the benefits of free and open competition.

24.2 In the event the Purchaser terminates the Contract in whole or in part, pursuant to Sub - Clause 24.1, the Purchaser may procure, upon such terms and in such manner as it deems appropriate, Goods or Services similar to those undelivered, and the Bidder shall be liable to the Purchaser for any excess costs for such similar Goods or Services. However, the Bidder shall continue performance of the Contract to the extent not terminated

### 25 Force Majeure

25.1 Notwithstanding the provisions of Clauses 22, 23, and 24, the Bidder shall not be liable for forfeiture of its performance security, liquidated damages, or termination for default if and to the extent that its delay in performance or other failure to perform its obligations under the Contract is the result of an event of Force Majeure.

25.2 For purposes of this clause, “Force Majeure” means an event beyond the control of the Bidder and not involving the Bidder’s fault or negligence and not foreseeable. Such events may include, but are not restricted to, acts of the Purchaser in its sovereign capacity, wars or revolutions, fires, floods, epidemics, quarantine restrictions, and freight embargoes.



## Section IV – General Condition of Contract

- 25.3 If a Force Majeure situation arises, the Bidder shall promptly notify the Purchaser in writing of such condition and the cause thereof. Unless otherwise directed by the Purchaser in writing, the Bidder shall continue to perform its obligations under the Contract as far as is reasonably practical, and shall seek all reasonable alternative means for performance not prevented by the Force Majeure event..
- 26. Termination for Insolvency** 26.1 The Purchaser may at any time terminate the Contract by giving written notice to the Bidder if the Bidder becomes bankrupt or otherwise insolvent. In this event, termination will be without compensation to the Bidder, provided that such termination will not prejudice or affect any right of action or remedy which has accrued or will accrue thereafter to the Purchaser
- 27. Termination for Convenience** 27.1 The Purchaser, by written notice sent to the Bidder, may terminate the Contract, in whole or in part, at any time for its convenience. The notice of termination shall specify that termination is for the Purchaser's convenience, the extent to which performance of the Bidder under the Contract is terminated, and the date upon which such termination becomes effective.
- 27.2 The Goods that are complete and ready for shipment within seven (7) days after the Bidder's receipt of notice of termination shall be accepted by the Purchaser at the Contract terms and prices. For the remaining Goods, the Purchaser may elect:
- a) to have any portion completed and delivered at the Contract terms and prices; and/or
  - b) to cancel the remainder and pay to the Bidder an agreed amount for partially completed Goods and Services and for materials and parts previously procured by the Bidder.
- 28. Settlement of Disputes** 28.1 If any dispute or difference of any kind whatsoever shall arise between the Purchaser and the Bidder in connection with or arising out of the Contract, the parties shall make every effort to resolve amicably such dispute or difference by mutual consultation
- 28.2 If, after thirty (30) days, the parties have failed to resolve their dispute or difference by such mutual consultation, then either the Purchaser or Bidder may give notice to the other party of its intention to commence arbitration, as hereinafter provided, as to the matter in dispute, and no arbitration in respect of this matter may be commenced unless such notice is given.
- 28.2.1 Any dispute or difference in respect of such a notice of intention to commence arbitration has been given in accordance with this Clause shall be finally settled by arbitration. Arbitration may be commenced prior to or after delivery of the Goods under the Contract.
- 28.2.2 Arbitration proceedings shall be conducted in accordance with the rules of procedure Specified in SCC.
- 28.3 Notwithstanding any reference to arbitration herein,
- a. the parties shall continue to perform their respective obligations under the Contract unless they otherwise agree; and
  - b. the Purchaser shall pay the Bidder any monies due the Bidder.



## Section IV – General Condition of Contract

- 29. Limitation of Liability** 29.1 Except in cases of criminal negligence or wilful misconduct, and in the case of infringement pursuant to Clause 6,
- (a) the Bidder shall not be liable to the Purchaser, whether in contract, tort, or otherwise, for any indirect or consequential loss or damage, loss of use, loss of production, or loss of profits or interest costs, provided that this exclusion shall not apply to any obligation of the Bidder to pay liquidated damages to the Purchaser and
  - (b) the aggregate liability of the Bidder to the Purchaser, whether under the Contract, in tort or otherwise, shall not exceed the total Contract Price, provided that this limitation shall not apply to the cost of repairing or replacing defective equipment.
- 30. Governing Language** 30.1 The Contract shall be written in the language specified in SCC. Subject to Clause 31, the version of the Contract written in the specified language shall govern its interpretation. All correspondence and other documents pertaining to the Contract which are exchanged by the parties shall be written in the same language
- 31. Applicable Law** 31.1 The Contract shall be interpreted in accordance with the laws of Nepal, unless otherwise specified in SCC.
- 32. Notices**
- 32.1 Any notice given by one party to the other pursuant to this Contract shall be sent to the other party in writing or by facsimile and confirmed in writing to the other party's address specified in SCC.
- 32.2 If a notice given pursuant to Sub Clause 32.1 fails to be delivered due to failure to trace the address of the party then the notice shall be published as public notice in a National daily newspaper and when the notice is so published then the notice shall be considered to be delivered to the concerned party.
- 32.3 A notice shall be effective when delivered or on the notice's effective date, whichever is later.
- 33. Taxes and Duties**
- 33.1 A foreign Bidder shall be entirely responsible for all taxes, stamp duties, license fees, and other such levies imposed outside Nepal.
- 33.2 A local Bidder shall be entirely responsible for all taxes, duties, license fees, etc., incurred until delivery of the contracted Goods to the Purchaser.
- 34. Bidder's Responsibilities** 34.1 The Bidder shall supply all the goods and related services included in the scope of supply and change order in accordance with GCC Clause 18 and the Delivery and completion schedule, as per GCC clause 10.
- 35. Purchaser's Responsibilities**
- 35.1 Whenever the supply of Goods and Rental Services requires that the Bidder obtain permits, approval and import and other licenses from local public authorities, the Purchaser shall, if so required by the Bidder, makes its best effort to assist the Bidder in complying with such requirements in a timely and expeditious manner.
- 35.2 The Purchaser shall pay all costs involved in the performance of its responsibilities, in accordance with sub-clause 35.1.
- 36. Extension of** 36.1 If at any time during performance of the Contract, the Bidder or its

## Section IV – General Condition of Contract

### Time

subcontractors should encounter conditions impeding timely delivery of the Goods or completion of related services pursuant to GCC clause 10, the Bidder shall promptly notify the Purchaser in writing of the delay, its likely duration, and its cause. As soon as practicable after receipt of the Bidder's notice, the Purchaser shall evaluate the situation and may at its discretion extend the Bidder's time for performance, in which case the extension shall be rectified by the parties by amendment of the Contract Unless otherwise specified in the Contract, if after the date of the Invitation for Bids, any law, regulation, ordinance, order or bylaws having the force of law is enacted, promulgated, abrogated, or changed in the place of Nepal where the site is located (which shall be deemed to include any change in interpretation or application by the competent authorities) that subsequently affects the delivery date and/or the Contract Price, then such delivery date and/or the Contract Price shall be correspondingly increased or decreased, to the extent that the Bidder has thereby been affected in the performance of any of its obligations under the Contract. Notwithstanding the foregoing. Such additional or reduced cost shall not be separately paid or credited if the same has already been accounted for in the price adjustment provisions where applicable, in accordance with GCC clause 17.



## Section V – Special Conditions of Contract

### SECTION V - SPECIAL CONDITIONS OF CONTRACT

The following Special Conditions of Contract shall supplement the General Conditions of Contract. Whenever there is a conflict, the provisions herein shall prevail over those in the General Conditions of Contract. The corresponding clause number of the GCC is indicated in parentheses.

#### 1. Definitions (GCC Clause 1)

- 1.1. (GCC 1.1 (k)) — The Purchaser is: Nepal Electricity Authority, Generation Directorate, Medium Generation O & M Department, Trishuli Hydro Power Station, Trishuli, Nuwakot, Nepal
- 1.2. (GCC 1.1 (l)) — The Supplier is the individual or firm to whom the contract has been awarded for Supply and Delivery of Goods under this Contract
- 1.3. (GCC 1.1 (n))—The delivery Site is: Trishuli Hydro Power Station, Trishuli, Nuwakot, Nepal.

#### 2. Country of Origin (GCC Clause 3)

All Goods and Services supplied under the Contract shall have their origin in Nepal or in all other countries and territories defined legally.

#### 3. Performance Security (GCC Clause 7)

- 3.1. (GCC 7.1)—Within Seven (7) days of receipt of the notification of Contract award, the Bidder shall furnish the performance security to the Purchaser. The amount of this security shall be five percent of the CONTRACT Price including vat. It shall be in the currency of Bid. In case of joint venture (J/V), the Performance Security shall be in the name of J/V
- 3.2. (GCC 7.3) In case the performance security is drawn from foreign bank, it shall be counter guaranteed from any acceptable bank from Nepal
- 3.3. (GCC 7.4) The validity of performance Security shall be at least one (1) month beyond the expiration of warranty period and will be discharged by the Purchaser and returned to the Supplier not later than Ninety (90) days following the date of completion of the Supplier's performance obligations under the Contract, including any warranty obligations and submission to Purchaser by the Supplier of Income Tax clearance certificate issued by concerned GON office. The supplier shall promptly extend the validity suitably to cover agreed extension of the warranty period of the supplied goods

#### 4. Inspections and Tests (GCC Clause 8)

All inspection and tests are to be made as defined in section VII. The inspection and test shall be done at 2 intervals during and after the repair works before the delivery to the purchaser's site in the presence of technical person on behalf of NEA at the contractor's expense. Bidder has to inform at least 7 days prior to NEA for inspection. Bidder has to provide transportation, accommodation and daily allowance as per the rules of NEA for minimum of 7 days during inspection period for one engineer.

#### 5. Packing (GCC Clause 9)

(GCC 9.2)—Additional requirement for packing and marking as per GCC Clause 9.2 are as follows:

- a) All external marking must be legibly and durably painted/stenciled on top sides of the packing.
- b) Part name, order number and the quantity must be shown on each packing.
- c) The package must be sealed by manufacturing company before dispatch of the goods.

#### 6. Delivery and Documents (GCC Clause 10)

(GCC 10.1) Delivery of the Goods/Services shall be provided by the Bidder in accordance with the terms specified in the Schedule of Requirements (Delivery Schedule).

- a. The Supplier shall deliver the GOODS/SERVICES to Purchaser warehouse sites as specified in the Bid Packages.
- b. The GOODS shall remain at the risk of the Supplier until delivery has been completed.



## Section V – Special Conditions of Contract

- c. Delivery is defined as the GOODS placed on the warehouse platform, dock, or ground after off-loading of the GOODS by the Supplier and all relevant shipping documents have been furnished to Purchaser. The GOODS supplied must be delivered into such stores as may be nominated by Purchaser and delivery will not be deemed to be complete until the cases/packages have been opened by the Contractor, their contents checked by Purchaser and the GOODS reprotected and repacked by the Contractor to the satisfaction of Purchaser, or assembled into units at Purchaser's option. Should there be any damage, defective or missing items (according to the packing list), the Contractor shall replace or repair such items immediately at his own expense.
- d. In case the Supplier fails to do so, Purchaser may replace or repair the same at the cost of the Contractor. d. Time of delivery is important and complete delivery of each item at the destination specified in the CONTRACT for each item assembled and ready for operation, shall be within the period specified in the Contract for each schedule or item
- e. Purchaser shall provide certification of receipt of all GOODS invoiced and delivered, in each instance, within thirty (30) calendar days. However, this certification of receipt shall not prejudice Purchaser's remedies stated in other Sections and Clauses for shipment received which contains damaged materials or missing materials.

### (GCC 10.3)—Documents to be submitted by the Supplier are as follows:

#### A. For Goods supplied from abroad:

Upon shipment, the Bidder shall notify the Purchaser and the Insurance Company by facsimile the full details of the shipment, including Contract number, description of Goods, quantity, the vessel, the bill of lading number and date, port of loading, date of shipment, port of discharge, etc. The Bidder shall mail the following documents to the Purchaser, with a copy to the Insurance Company:

- (i) copies of the Bidder's invoice showing Goods' description, quantity, unit price, and total amount;
- (ii) original and copies of the negotiable, clean, on-board bill of lading marked "freight prepaid" and copies of nonnegotiable bill of lading;
- (iii) copies of the packing list identifying contents of each package;
- (iv) insurance certificate;
- (v) Manufacturer's or Bidder's warranty certificate;
- (vi) inspection certificate, issued by the nominated inspection agency, and the Bidder's factory inspection

6.2 The documents as per sub-clause 6.1 shall be received by the Purchaser at least one week before arrival of the Goods at the port or place of arrival and, if not received, the Bidder will be responsible for any consequent expenses.

#### B. For goods within Nepal:

Upon delivery of the Goods to the transporters, the Bidder shall notify the Purchaser and mail the following documents to the Purchaser:

- (i) copies of the Bidder's invoice showing Goods' description, quantity, unit price, and total amount;
- (ii) delivery note, railway receipt, or truck receipt;
- (iii) Manufacturer's or Bidder's warranty certificate;
- (iv) inspection certificate issued by the nominated inspection agency, and the Bidder's factory inspection report; and
- (v) Certificate of origin.

6.3 The documents as per sub-clause 6.3 shall be received by the Purchaser before arrival of the Goods and, if not received, the Bidder will be responsible for any consequent expenses.



## Section V – Special Conditions of Contract

### 7. Insurance (GCC Clause 11.1)

- a. Bidder has to make insurance of the Runners prior to the transportation from/to the site and submit the necessary insurance policy evidence before transportation
- b. The Supplier shall provide and maintain insurance applying to all shipments of GOODS with continuous coverage from the factory to Purchaser designated warehouse. Such insurance shall be with an insurance company presently authorized to conduct business in Nepal.
- c. The Supplier shall provide marine insurance, if sea transportation is required, and all insurance coverage for inland transportation to Purchaser warehouse sites as specified in the Bid Packages
- d. The insurance provided shall cover all risks, and the minimum limits of insurance shall be the total cost plus ten percent of the materials delivered to Purchaser warehouse sites as specified in the Bid Packages
- e. The Purchaser shall file with Purchaser properly executed certificates of insurance or copies of insurance policies before commencing shipment. These certificates shall be mailed in accordance with the provisions of Clause herein.  
Certificates of insurance shall contain the following information:
  - i. Name and address of the insurance company, policy number and expiration date.
  - ii. Signatures of insurance company representative or agent and address thereof
  - iii. Types of coverage and limits of insurance.
  - iv. A statement indicating that Purchaser shall receive at least thirty (30) days advance written notice of cancellation of any of the policies or modifications of the insurance.
- f. The Supplier shall be responsible for and ensure that subcontractors, if any, maintain the same insurance and comply with the same provisions required of the Supplier.
- g. The furnishing of the foregoing insurance by the Supplier shall not limit any of the obligations or liabilities of the Supplier imposed under this CONTRACT or by laws of Nepal.
- h. In the event that, prior to acceptance by Purchaser any material is lost or damaged to the extent that in the opinion of Purchaser it cannot be used, the Supplier agrees to make immediate shipment or replacement material upon notification by Purchaser of the types and quantities of materials to be replaced. The shipment of replacement material shall not be delayed pending investigation of the cause of such loss or damage or by the filing and processing of insurance claims. If Purchaser agrees that any damaged material may be repaired instead of requiring replacement, the Supplier agrees to effect the repairs to the satisfaction of Purchaser as promptly as possible and to pay the full cost thereof
- i. The Supplier agrees to prepare and submit to the insurance carrier all claims for loss or damage. Purchaser will assist the Supplier in compiling the needed information or data to identify the materials lost or damaged. The Supplier agrees that any payment resulting from insurance claims will be made by the insurance carrier to the Supplier and will constitute full and complete compensation for the replacement material.

*The Insurance shall be in an amount equal to 110 percent of the CIF or CIP value of the Goods from “warehouse” to “warehouse” on “All Risks” basis, including War Risks and Strikes. The insurance should cover the value not less than NRs.7,000,000.00 for each turbine runner*

### 8. Transportation (GCC Clause 12)

**(GCC 12.1)**—Obligation and responsibility of transportation of the goods shall be in accordance with the current edition of INCOTERMS published by the International Chamber of Commerce, Paris. It would be in the Bidders scope to transport the goods from/to the site (THPS) for the repair works.

### 9. Incidental Services (GCC Clause 13)

GCC 13.1—Incidental services to be provided are:

- (i) Installation and commissioning of equipment;
- (ii) Shop inspection and testing of the equipment.

### 10. Spare Parts (GCC Clause 14) NA

### 11. Warranty (GCC Clause 15)



## Section V – Special Conditions of Contract

### 11.1. (GCC 15.1) –

- a. Contract are new, unused, proposed type/spec meets purchaser's requirements. It's standard in respect of design, materials selection and manufactured and also tested as per relevant ISO or equivalent standard unless provided otherwise in the Contract. The Supplier further warrants that all Goods supplied under this Contract shall have no defect, arising from spec, materials, Sizes or workmanship or from any act or omission of the Supplier, that may develop under normal use of the supplied Goods in the conditions prevailing in the country of final destination.
- b. The supplier shall comply with the performance guarantees for intended application. If, for reasons attributable to the supplier, these guarantees do not meet in whole or in part, the supplier shall, at its discretion , either : i. make such changes, modification &/or addition to the Goods or any part thereof as may be necessary in order to attain the purpose at its own cost and expense. ii. Pay liquidated damages to the purchaser with respect to the failure to meet the goal. The rate of liquidated damage shall be 0.5% per day.

### 11.2. (GCC 15.2)—

- a) The warranty period shall be 12 months for the GOODS after delivered to and accepted at site.
- b) The Bidder has to arrange the service at site within 7 (seven) days when required by the purchaser during the warranty period.

11.3. (GCC 15.4)—The period for correction of defects in the warranty period is: 25% time of the delivery schedule (provided first time) of the particular goods/Services

## 12. Payment (GCC Clause 16)

12.1. GCC 16.1—The method and conditions of payment to be made to the Bidder under this Contract shall be as follows:

- A. Payment for Goods/services supplied: Payment for Goods supplied from abroad shall be made, as follows:
  - i. Letter of Credit: Letter of Credit can be opened within thirty (30) days of signing of the Contract (for import of service from foreign country).
  - ii. Advance Payment: Ten (10) percent of the contract price (CIF site) of the goods can be paid after signing of the contract against a simple receipt and a bank guarantee for the equivalent amount and appropriate period (covering the work completion period) and in the form provided in the bidding documents or another form acceptable to the Purchaser.
  - iii. On Acceptance: Remaining payment of Goods received shall be paid within thirty (30) days of receipt of the Goods upon submission of claim supported by the acceptance certificate issued by the Purchaser.
  - iv. Five (5) percent of the invoice value shall be withheld as retention. The retention thus held shall be paid after the issuance of the Final Acceptance Certificate for the complete Works by the Employer at the expiry of the warranty period or against the bank guarantee having validity to cover the warranty period.
  - v. Income tax will be deducted as per GoN rule.
- B. Payment for Goods/services supplied: Payment for Goods supplied within country shall be made, as follows:
  - i. Payments shall be made in Nepalese currencies
  - ii. Payment will be made after the goods received at site in good condition and after approval of conformity of comply from the engineer at site.
  - iii. Payment shall be made within 30 days after approval of the Invoice/Goods by the incharge Engineer.
  - iv. Five (5) percent of the invoice value shall be withheld as retention. The retention thus held shall be paid after the issuance of the Final Acceptance Certificate for the complete Works by the Employer at the expiry of the warranty period.
  - v. Income tax will be deducted as per GoN rule.



## Section V – Special Conditions of Contract

### 13. Prices (GCC Clause 17)

- 13.1. (GCC 17.1) — The Price is not subject to adjustment.
- 13.2. Purchaser shall not entertain Contract Price variation due to the effect of any notice of exchange rate variation of any convertible currency.
- 13.3. Conversion of any convertible currency into the Nepali currency, if in any case required, shall be in the base of selling exchange rate established by the Nepal Rastra Bank.

### 14. Liquidated Damages (GCC Clause 23)

- 14.1. (GCC 23.1) —
  - a. Liquidated damages for delay in performance is: 0.05% of the contract price per day with maximum deduction not to exceed ten (10) percent of the contract price.
  - b. The completion time of delivery of GOODS is of the essence. Should the Supplier neglect, refuse, or fail to deliver the GOODS/SERVICES within the time herein agreed upon or after giving effect to any extensions of time herein provided, Liquidated Damage for each and every calendar day that such delivery of GOODS is delayed shall be imposed.
  - c. Liquidated damage shall be imposed only upon those schedule/goods which the bidder cannot maintain/provide according to the purchaser's requirement

### 15. Settlement of Disputes (GCC Clause 28)

#### 15.1. GCC 28.2.2—Arbitration Proceedings:

- (i) Any dispute or difference arising between the Supplier and Purchaser under the CONTRACT shall not be referred to Arbitration unless an attempt has first been made to settle the same amicably
- (ii) If, at any time, any dispute, difference or protest arises between the Supplier or Purchaser which cannot be settled amicably, either party shall give to the other a notice in writing to settle the same through arbitration.
- (iii) To conduct the arbitration proceeding, a Board of Arbitrators shall be set up. Each party shall select and appoint one arbitrator, and the two arbitrators so selected and appointed shall jointly select and appoint a third arbitrator to complete the Board of Arbitrators. The opinion of the majority of the Board of Arbitrators shall be decisive, final and binding upon the parties. The arbitration proceeding shall be conducted in Nepal in accordance with the Arbitration Act-2038 of Nepal.
- (iv) Provided always that pending the final award of the Arbitrators the Supplier shall comply with the instruction of Purchaser and proceed with due diligence in the manner directed by Purchaser.
- (v) Each party, Purchaser and the Supplier, shall bear the cost of its own arbitrator's service. The cost of the third arbitrator's service shall be allocated between the parties in proportion decided by the Board of Arbitrators.
- (vi) in the case of a dispute between the Purchaser and a Bidder which is a national of Nepal, the dispute shall be referred to arbitration in accordance with the rules of Nepal Council of Arbitration ; and
- (vii) in the case of dispute between the Purchaser and the Foreign Bidder, the dispute shall be settled by arbitration in accordance with the provisions of the United Nations Commission on International Trade Law (UNCITRAL) Arbitration Rules.

### 16. Governing Language (GCC Clause 30)

- 16.1. (GCC 30.1) —The Governing Language shall be: English but correspondence may be done in Nepali.

### 17. Applicable Law (GCC Clause 31)

- 17.1. (GCC 31.1) —The Applicable Law shall be: The laws of Nepal

### 18. Notices (GCC Clause 32)



## Section V – Special Conditions of Contract

- 18.1. (GCC 32.1) —Purchaser's address for notice purposes: Nepal Electricity Authority, Generation Directorate, Medium Generation O & M Department, Trishuli Hydro Power Station, Trishuli, Nuwakot  
Bidder's address for notice purposes .....

### 19. Taxes and Duties (GCC Clause 33)

- 19.1. (GCC 33.1) —A foreign Bidder shall be responsible for all duties and taxes imposed until the delivery of Goods to the Purchaser both outside and inside Nepal. But the price schedule shall be filled up excluding custom duty and VAT. 20.2  
19.2. (GCC 33.2) —A local Bidder shall be responsible for all duties, taxes, license fees etc. incurred until delivery of the contracted Goods to the Purchaser.

### 20. Extension of Time (GCC 36.1)

The addition to the clause are as follows:

Supplier shall make such request seven (7) days prior to the date of actual delivery date as per the delivery schedule.



**Section VI – Schedule of requirement**

**SECTION VI - SCHEDULE OF REQUIREMENTS**

The delivery schedule expressed as weeks/months stipulates hereafter a delivery date which is the date of delivery

- (iv) at EXW premises, or
- (v) to the carrier at the port of shipment when the contract is placed on FOB or CIF terms, or
- (vi) to the first carrier when the contract is placed on FCA or CIP terms. In order to determine the correct date of delivery hereafter specified, the Purchaser has taken into account the additional time that will be needed for international or national transit to the Project Site or to another common place.

Purchaser's requirement

Bidder's schedule:

1. Transport – Repair work– Delivery 60 days

.....

THE DELIVERY SCHEDULE SHALL BE EFFECTIVE FROM WHEN ALL OF FOLLOWING CONDITIONS WILL BE FULFILLED, unless and otherwise mentioned in contract agreement.

(i) Contract award, (ii) the date of contract signature

The Bid Form should include only a cross-reference to this Schedule.



## Section VII – Work Requirements

### SECTION VII - WORKS REQUIREMENTS

This Section contains the Specification, Drawings, and supplementary information that describe the Works to be procured.

#### 7.1 INTRODUCTION

Trishuli Hydropower Station which is Located at Trishuli in District of Nuwakot 78 kms from Kathmandu by road. The power station has been built as the run of the river project and houses 7 generating machines of 3.5 MW capacity having Francis type turbines as their prime mover. These turbines during monsoon season suffer considerable damages due to excessive silt of river Trishuli on the runners and its accessories and necessitate their repair as well as procurement of new spares in order to limit further damage and make them operation worthy for next High flow high silt season. In order to meet this requirement, THPS aims to repair three number francis runners

#### 7.2 SCOPE OF WORK.

The scope of work under this covers the RUNNER REPAIR WORKS FOR UNIT 3 and 5 for THPS Nepal. Bidders are advised to visit the site and see the used Turbine parts physically before submitting the bid and also for necessary data and information along with drawing if necessary.

The runner blade thickness at inlet and exit blade area shall be mapped before repair preferably using ultra sonic measurement method or any alternative suitable method prior approved by THPS. Testing for identification of cracks / porosity etc in base metal shall also be done in presence of employer's verification so as to suitably treat such location.

The contractor shall develop suitable templates for checking of final blade profile both at inlet and outlet before starting of repair work. Such templates shall be approved by THPS before starting of repair work. The templates shall be checked for the trueness of the dimension / profile with respect to the available runner drawing. All templates so manufactured shall become the property of THPS after inspection of the runner and shall be handed over along with repaired runner.

It will the sole responsibility of the bidder to abide by the terms stated in SCC (Insurance and transportation) Employer reserve the right to decline the acceptance of the Goods, which to its own judgment are not found suitable for the intended use.

#### 7.3 QUALIFICATION OF BIDDERS/MANUFACTURERS:

##### A. if the bidder is manufacturer

- The bidder must have experienced and qualified-in-house Mechanical Engineers having experience in casting and machining works and standard welder for maintaining the quality welding on the hydro mechanical parts; qualification records are to be valid for the time of work. The bidder must submit the notarized copy of documentary evidence for this along with bid document.
- The bidder must have a suitable facility of at least, but not limited to:
  - i. Lathe of turning capacity at least for 1.5m for machining of the turbine parts
  - ii. Overhead crane with electrical equipped hoist system of at least 2 tons
  - iii. Planner, Milling and Radial Drilling Machine
  - iv. Electric or Diesel air compressor
  - v. Mobile crane and fork lift at least 10 ton capacity
  - vi. Suitable Welding, Grinding or Polishing Facility
  - vii. Radiographic test facility, Dye Penetration, Ultrasonic test Facility, Magnetic Particle test facility for checking surface defects and weld quality
  - viii. Fully equipped heat treatment facility
- Bidders should submit documentary evidence in support of their fulfillment of above requirements along with the bid otherwise the bid should be rejected for evaluation purpose.



## Section VII – Work Requirements

### B. if the bidder is non manufacturer

- he/she should produce authorization letter from industry/contactor from whom the work shall be procured

## 7.4 TECHNICAL SPECIFICATION FOR FRANCIS RUNNER

The required dimensions of the runner parts can be referred from the drawing attached with the bid document

### Salient features of the Francis runner

|                             |   |
|-----------------------------|---|
| Type                        | Single runner driven horizontal shaft Francis |
| No. of Units                | 7   |
| Rated output/unit           | 3620 kW                                       |
| Rated Flow/Unit @ peak load | 7.88 m <sup>3</sup> /s                        |
| Design Net Head             | 51.4  |
| Rated Speed                 | 500 rpm                                       |
| Weight                      | 900 KG  |
| Material                    | 00Cr16Ni5Mo                                   |

### Technical Details of Repairing Procedure

1. Suitable electrodes with required chemistry of grade specified Technical datasheet for repairing. This section dried at specified temperature of any of the aforesaid makes shall be used for rebuilding the eroded areas of the Runner
2. The complete worn out (missing) part of Runner, if any, shall be repaired by weld deposition through specified electrode of same material as of existing guide vane. The contractor shall select the repairing method as approved by NEA"s engineer. The bidder shall use specified electrodes supplied in vacuum packs and manufactured by any of the below mentioned approved manufacturers. The welding electrode to be used must be preheated in oven to the required temperature for at least 24 hrs before used.
  - Bohler Fox.
  - Weld Alloy Products
  - Larsen & Toubro
  - AdvaniOerlikon Ltd
  - D & H Scheron

The material will be heat treated to obtain a homogeneous and fine grained micro structure. Testing for identification of cracks / porosity etc in base metal shall also be done before treatment.

### Static Balancing and heat treatment of the runner

The scope of work also covers the design and fabrication of runner-specific mandrels to be used for static balancing. The specification also covers the static balancing of runner as per requirement of manufacturer of runner in presence of THPS engineer after completion of all repair works and heat treatment of complete refurbished runner. The bidder shall also provide report of balancing along with the other documentation to THPS for record purpose. Facility for static balancing shall be handed over to THPS during the delivery of runners. Bidder also has to submit the detail as built drawing of static balancing setup.

The bidder shall carry out stress relieving of the repaired runner as per the relevant applicable standard. The bidder shall also submit a detailed procedure for THPS approval before the performance of the



## Section VII – Work Requirements

Stress Relieving. Since the repair work involved may result into distortions, bidder has to take all required precaution so as to maintain the dimension of the runner and other turbine parts within the tolerance.

### 7.5 INSPECTION & QUALITY CONTROL

The bidder and all of his suppliers or Sub-contractors shall have a fully established and quality control system certified under ISO9001. The Contractor shall submit the detail NDT procedure in separate Quality Assurance Plan (QAP) for approval to the Engineer and shall obtain Engineer's approval before the inspection is made. The Engineer shall have the right to add further NDT inspection of the welded lines when needed. Should the Engineer, during his inspections or otherwise, determine that this system is not sufficiently effective, based on:

- formal errors in contradiction to the established procedures and/or
- manufacturing deficiencies
- and/or non-acceptable test results and missing tests

The Engineer may, at his entire discretion and at the full expense of the Contractor, impose such additional tests and inspections as deemed necessary to assure the quality of manufacturing and performance as stipulated by the terms of the Contract.

The bidder shall be required to devise the work instructions / activities so as to achieve the specified dimension, profile and surface finish of entire runner as per the satisfaction of NEA engineer.

- During the repair, inspection of the work shall be carried out by authorized representative of NEA. The contractor shall inform NEA at least 7 days ahead of impending inspection stage.
- NEA authorized representative or third party inspection agency, as desired by THPS, shall carry out inspection of job at various stages of repair works as per relevant IS/BS/ASTM/ASME standards.

### 7.6 NON DESTRUCTIVE TESTS (NDT)

#### i. Ultrasonic Examination

Ultrasonic examination and acceptance standards for welds other than spiral welds must be in accordance with Paragraph UW 53 and Appendix 12 of the ASME Code, Section VIII, Division 1 or equivalent.

#### ii. Magnetic Particle (Test) Examination

All the weld seam shall be magnetic particle tested. Magnetic particle examination techniques are described in the ASME Code, Section V, and Article 7 and in ASTM 709 or equivalent. Acceptance criteria must conform to the requirements of Appendix 6 of the ASME Code, Section VIII, Division 1 or equivalent.

#### iii. DYE Penetration Test

Dye penetrates examination procedures must conform to the requirements of the ASME Code, Section V, Article 6 or equivalent. Acceptance criteria must conform to the requirements of Appendix 6 of the ASME Code, Section VIII, Division 1 or equivalent.



Section VII – Work Requirements

Runner assembly for Unit 1-3 (MHDC dwg no. 86J5138)

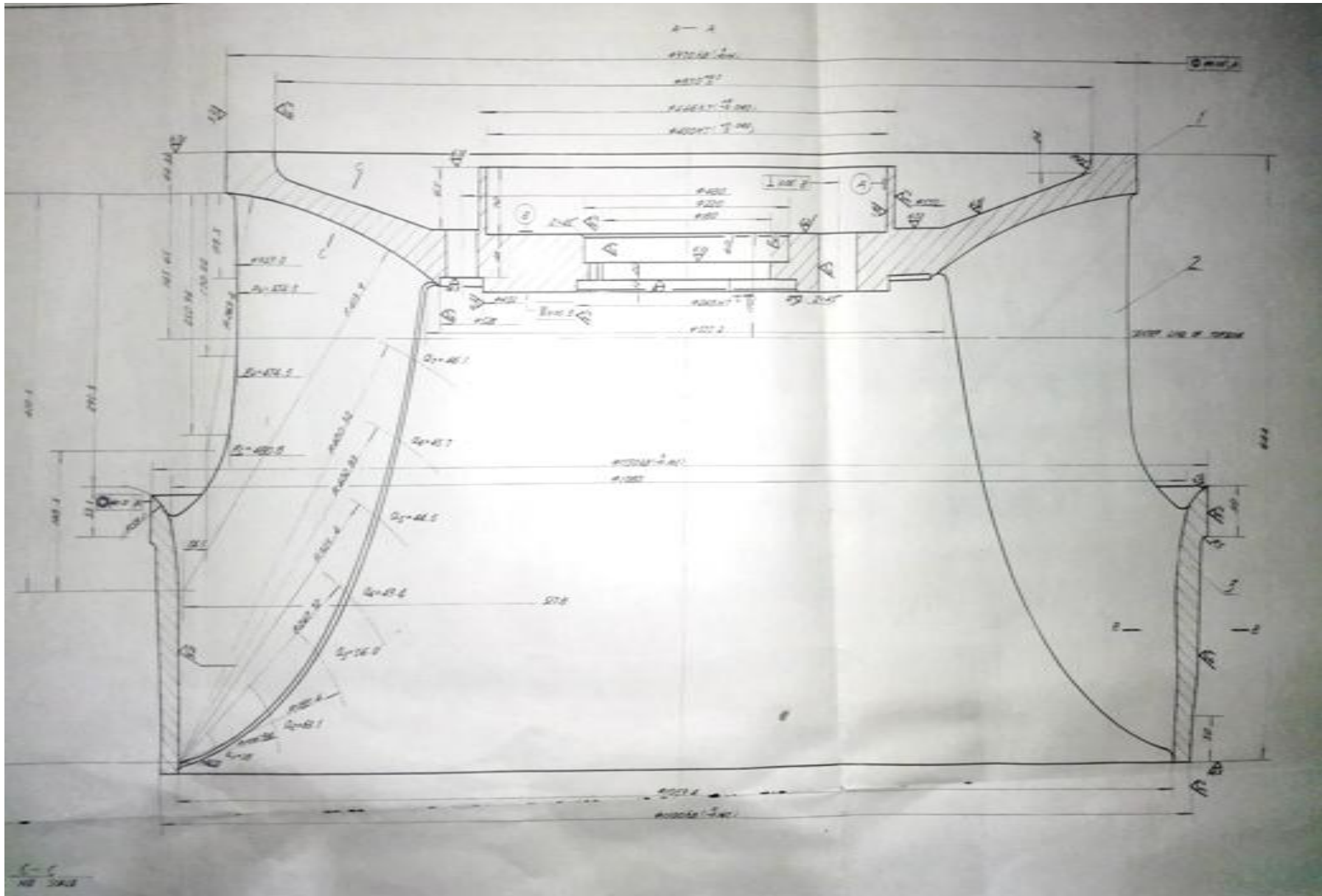



**Section VII – Work Requirements**

**Final dimension after machining  
(Unit 3)**

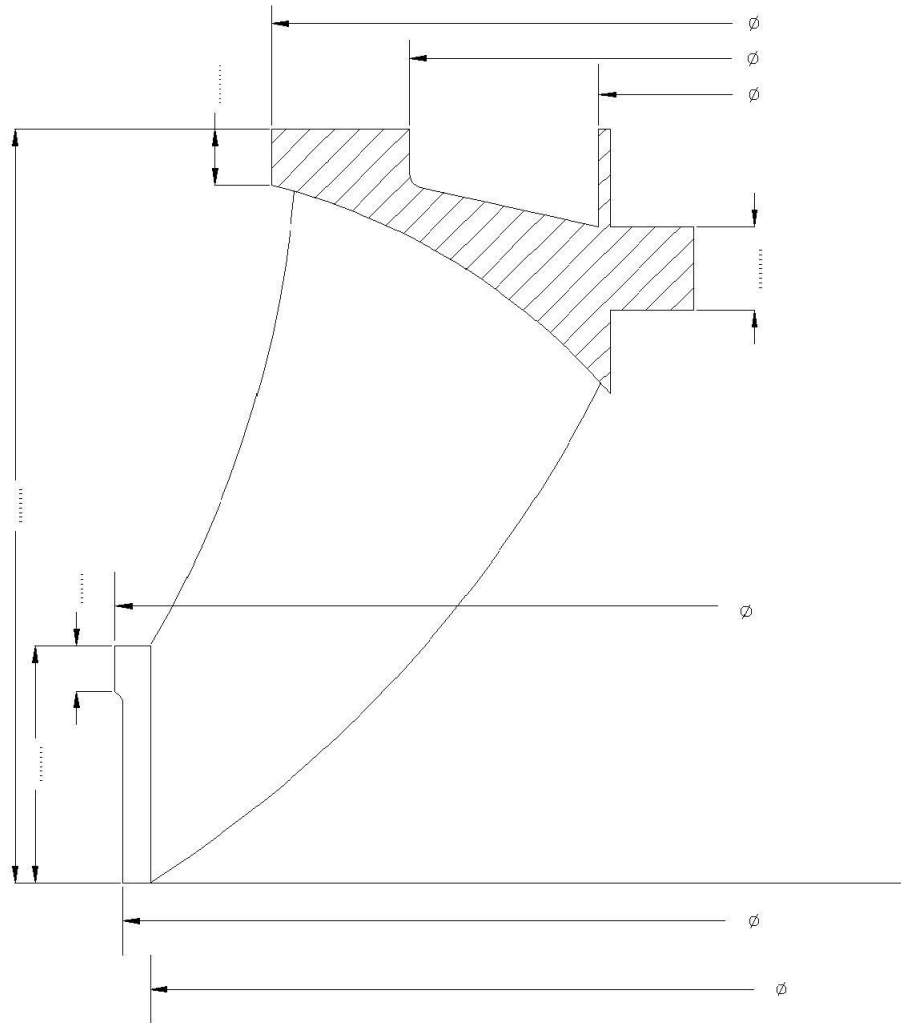

Francis Runner Section Template for Unit 3  
Dwg only for referring Basic dimensions

**Date:**  
**Measured by:**



**Section VII – Work Requirements**

**Final dimension after machining  
(Unit 3)**

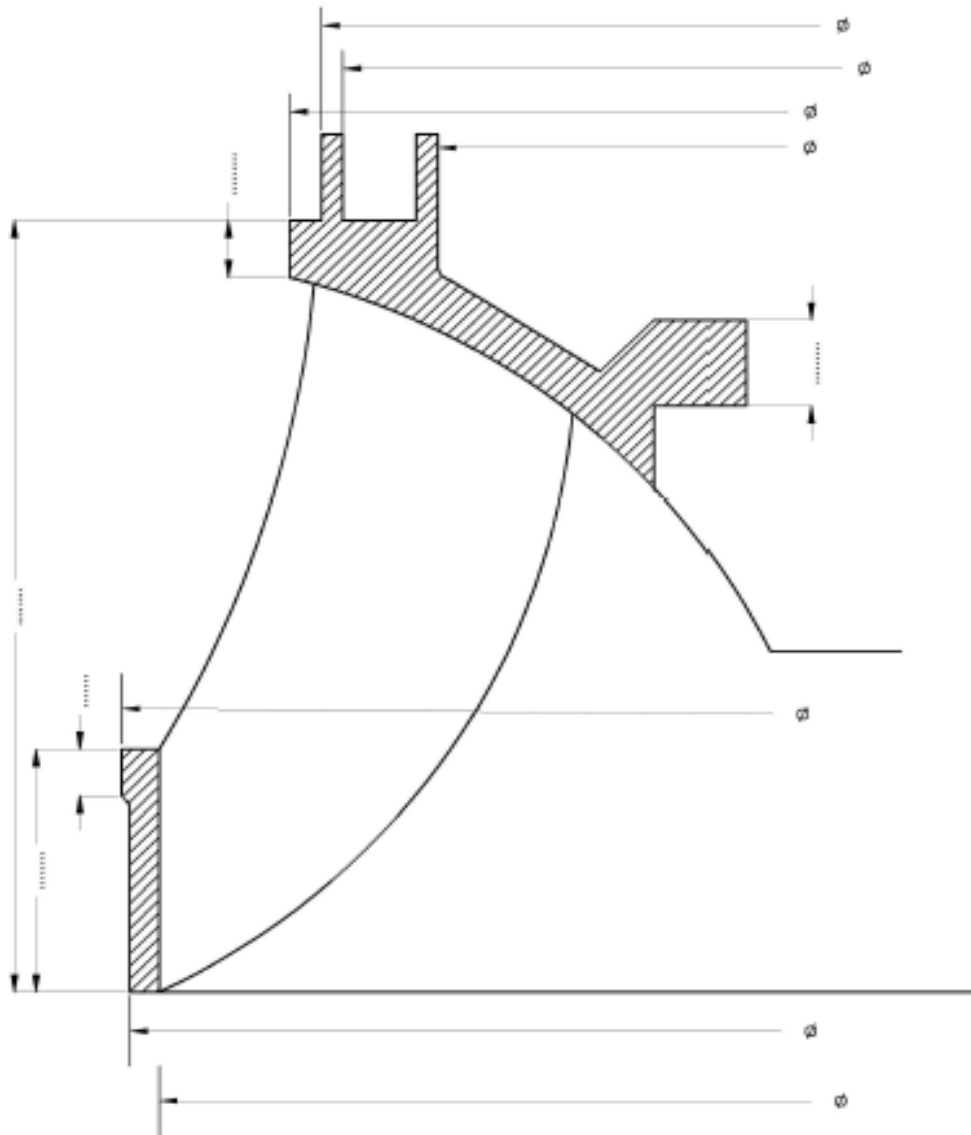

Francis Runner Section Template for Unit 5  
Dwg only for referring Basic dimensions

**Date:**  
**Measured by:**



## Section VII – Work Requirements

### 7.7 TECHNICAL DATA SHEET OF MANUFACTURING OF TURBINE PARTS FOR UNIT 1,3

| S No. | Description                                      | NEA requirement  | Filled by Bidder | Remarks  |
|-------|--|--|------------------|--|
| 1     | location of repairing workshop                   |  |                  |  |
| 2     | parent material                                  | specified by NEA   |                  | for individual parts   |
| 3     | Dimension/Tolerance                              | As per drawings  |                  | to be specified by NEA   |
| A.    | Runner repair for Unit 3                         |  |                  |  |
| B.    | Runner repair for Unit 5                         |  |                  |  |
| 4     | Manufacturer/Bidder's valid ISO 9001 certificate | to be submitted  |                  |  |
| 5     | Manufacturer's Authorization                     | to be submitted  |                  |  |
| 6     | Brand/Manufacturer of welding rods               | to be submitted  |                  |  |
| 7     | End User's certificate                           | To be submitted on the official letterhead of end user                                       |                  | Evidence of repair of francis runner of 3.5MW or higher required |
| 8     | Specification of welding electrode               | As parent metal (A307: compatible with 00Cr16Ni5Mo as per drawing 86J5138, 86J5134, 86J5142) |                  | Mandatory Submission of:   |
|       |  |  |                  | Manufacturer' valid ISO  |
|       |  |  |                  | Catalogue for Chemical composition                               |
|       |  |  |                  | Catalogue for Physical properties                                |
| 9     | Details of necessary equipment                   | to be submitted  |                  | Documentary evidence required                                    |
| 10    | Details of tests facilities                      | to be submitted  |                  | Documentary evidence required                                    |
| 12    | Welders qualification certificates               | 6G Standard (To be Submitted)  |                  | Certificates should be as per requirement of AWS norms           |

#### **NOTE**

**Bidders are strictly advised to submit the specified documents in Technical Data Sheet and documentary evidence as per Section 7.3 during the submission of hard copy. NEA (purchaser) hereby reserves the right to reject the bidder's proposal during the evaluation process which doesn't carry the complete set of documents with its own judgment.**

## SECTION VIII - BID FORMS, PRICE SCHEDULE & SAMPLE FORMS

### 1. Quotation and Price Schedules

Date:

To,

The chief,  
Trishuli Hydropower Station,  
Nepal Electricity Authority,  
Trishuli, Nuwakot.

Gentlemen and/or Ladies:

Having examined the Bid documents, we the undersigned, offer to supply and deliver, **RUNNER REPAIR WORKS FOR UNIT 3,5** in conformity with the said BID documents for the sum of *[total BID amount in words and figures* .....  
.....  
.....] or such other sums as may be ascertained in accordance with the Schedule of Prices attached herewith and made part of this BID.

We undertake, if our BID is accepted, to deliver the goods in accordance with the delivery schedule specified in the Schedule of Requirements.

We agree to abide by this BID for a Period of .....days from the date fixed for BID opening it shall remain binding upon us and may be accepted at any time before the expiration of that period.

Until a formal Contract is prepared and executed, this BID, together with your written acceptance thereof and your notification of award, shall constitute a binding Contract between us.

We understand that you are not bound to accept the lowest or any BID you may receive.

Dated this \_\_\_\_\_ day of \_\_\_\_\_ 2017\_\_\_\_\_.

\_\_\_\_\_  
[signature]

\_\_\_\_\_  
[in the capacity of]

Duly authorized to sign BID for and on behalf of \_\_\_\_\_



**Section VIII – Bid forms, Price Schedule & Sample Forms**

**NEPAL ELECTRICITY AUTHORITY**  
**Medium Generation, Operation & Maintenance Department**  
**Trishuli Hydro Power Station, Trishuli, Nuwakot, Nepal**

**BOQ:-RUNNER REPAIR WORKS FOR UNIT 3, 5**

| S.No.                    | Description of Work  | Qty | Unit | Unit Rate | Total Amount |
|--------------------------|--|-----|------|-----------|--------------|
|                          |  |     |      | NRs.      | NRs.         |
| 1                        | Repairing of <b>Francis runner (UNIT-3)</b> including preparation, packing, transportation to and from workshop, loading/ unloading, accidental insurance during transportation and all other related services | 1   | Set  |           |              |
| 2                        | Repairing of <b>Francis runner (UNIT-5)</b> including preparation, packing, transportation to and from workshop, loading/ unloading, accidental insurance during transportation and all other related services | 1   | Set  |           |              |
| 3                        | Static Balancing of Francis Runner including all the necessary jigs and setups   | 2   | Set  |           |              |
| 4                        | Magnetic Particle Testing for weld joints  | 2   | Set  |           |              |
| <b>Total, NRs.</b>       |  |     |      |           |              |
| <b>VAT 13%</b>           |  |     |      |           |              |
| <b>Grand Total, NRs.</b> |  |     |      |           |              |

Total Price up to Trishuli Hydro Power Station, Trishuli, Nuwakot, Nepal  
 (in Words).....

Signature of Bidder:

Company Seal:

|                      |  |
|----------------------|--|
| <b>Company Name</b>  |  |
| <b>Address</b>       |  |
| <b>Telephone</b>     |  |
| <b>Mobile No.</b>    |  |
| <b>Fax No.</b>       |  |
| <b>Email Address</b> |  |

**Bidders are strictly advised to duly fill up the contact form**



**Section VIII – Bid forms, Price Schedule & Sample Forms**

**2. BID FORM**

We have examined the documents listed in Instruction to Bidders, Clause 3 and offer to execute the Works in conformity with the Contract for the sum of ..... (in words) ..... (in figures) or such other sum as may be ascertained under the contract.

This bid shall remain binding until \_\_\_\_\_ [date]. This bid and your written acceptance of it shall constitute a binding contract between us.

We understand that the Employer is not bound to accept the lowest or any offer received for the Works.

Signature \_\_\_\_\_ Date: \_\_\_\_\_

Name : \_\_\_\_\_ Authorised to sign on behalf of (organisation name):

**Designation:** \_\_\_\_\_



**Section VIII – Bid forms, Price Schedule & Sample Forms**

**3. Bid Security**

Date :

To:

The chief,

Trishuli Hydropower Station,

Nepal Electricity Authority,

Trishuli, Nuwakot.

Whereas, *[name of Bidder]* (hereinafter called “the Bidder”) has submitted his Sealed Quotation (BID) dated *[date of submission of BID]* for the supply of *[name and/or description of the goods]* (hereinafter called “the Sealed Quotation”).

KNOW ALL PEOPLE by these presents that WE *[name of Bank]* of Nepal having our registered office at *[address of bank]* (hereinafter called “the Bank”) are bound unto *[name of the procuring entity]*(hereinafter called “the Purchaser”) in the sum of *[specify amount in figure and words]*for which payment well and truly to be made to the said Purchaser, the Bank binds itself, its successors, and assigns by these presents. Sealed with the Common Seal of the said Bank this \_\_\_\_\_ day of \_\_\_\_\_ 2017\_\_\_\_\_.

THE CONDITIONS of this obligation are:

- (1) If, the Bidder withdraws its BID during the period of bid validity specified by the Bidder on the BID Form; or
- (2) If the Bidder having been notified of the acceptance of its BID by the Purchaser during the period of bid validity:
  - (a) fails or refuses to execute the Contract Form, if required; or
  - (b) fails or refuses to furnish the performance security, in accordance with the Instruction to Bidders;

we undertake to pay to the Purchaser up to the above amount upon receipt of its first written demand, without the Purchaser’s having to substantiate its demand, provided that in its demand the Purchaser will note that the amount claimed by it is due to it owing to the occurrence of one or both of the two conditions, specifying the occurred condition or conditions.

This guarantee will remain in force up to ninety (75) days from the date of opening of the Sealed Quotation, and any demand in respect thereof should reach the Bank not later than the above date

\_\_\_\_\_

*[signature of the bank]*

\_\_\_\_\_

*[common seal of the bank]*



**Section VIII – Bid forms, Price Schedule & Sample Forms**

**4. Form of Agreement**

THIS AGREEMENT made the \_\_\_\_\_ day of \_\_\_\_\_ 2017\_\_\_\_\_ between NEA (hereinafter called “the Purchaser”) of the one part and [name of Supplier] of [city and country of Supplier] (hereinafter called “the Supplier”) of the other part:

WHEREAS the Purchaser invited Sealed Quotation for certain goods and ancillary services, viz., [brief description of goods and services] and has accepted a BID by the Supplier for the supply of those goods and services in the sum of [contract price in words and figures] (hereinafter called “the Contract Price”).

NOW THIS AGREEMENT WITNESSETH AS FOLLOWS:

1. In this Agreement words and expressions shall have the same meanings as are respectively assigned to them in the Conditions of Contract referred to.
2. The following documents shall be deemed to form and be read and construed as part of this Agreement, viz.:
  - a. Quotation Form and the Price Schedule submitted by the Supplier;
  - b. The Schedule of Requirements;
  - c. The Technical Specifications;
  - d. The Conditions of Contract; and
  - e. The Purchaser’s Notification of Award.
3. In consideration of the payments to be made by the Purchaser to the Supplier as hereinafter mentioned, the Supplier hereby covenants with the Purchaser to provide the goods and services and to remedy defects therein in conformity in all respects with the provisions of the Contract.
4. The Purchaser hereby covenants to pay the Supplier in consideration of the provision of the goods and services and the remedying of defects therein, the Contract Price or such other sum as may become payable under the provisions of the contract at the times and in the manner prescribed by the Contract.

IN WITNESS whereof the parties hereto have caused this Agreement to be executed in accordance with their respective laws the day and year first above written.

On behalf of the Purchaser

On behalf of the Supplier

Name:

Name:

Designation:

Designation:

Sign:

Sign:

Seal:

Seal:



**Section VIII – Bid forms, Price Schedule & Sample Forms**

**4. Performance Security**

Date :

To:

The chief,  
Trishuli Hydropower Station,  
Nepal Electricity Authority,  
Trishuli, Nuwakot.

WHEREAS [*name of Supplier*] (hereinafter called “the Supplier”) has undertaken, in pursuance of Contract No. [*reference number of the contract*] dated \_\_\_\_\_ 2017 \_\_\_\_\_ to supply [*description of goods and services*] (hereinafter called “the Contract”).

AND WHEREAS it has been stipulated by you in the said Contract that the Supplier shall furnish you with a bank guarantee by a reputable bank for the sum specified therein as security for compliance with the Supplier’s performance obligations in accordance with the Contract.

AND WHEREAS we have agreed to give the Supplier a guarantee:

THEREFORE WE hereby affirm that we are Guarantors and responsible to you, on behalf of the Supplier, up to a total of [*amount of the guarantee in words and figures*], and we undertake to pay you, upon your first written demand declaring the Supplier to be in default under the Contract and without cavil or argument, any sum or sums within the limits of [*amount of guarantee*] as aforesaid, without your needing to prove or to show grounds or reasons for your demand or the sum specified therein.

This guarantee is valid until the \_\_\_\_\_ day of \_\_\_\_\_ 2017 \_\_\_\_\_.

Signature and seal of the Guarantors

\_\_\_\_\_  
[*name of bank or financial institution*]

\_\_\_\_\_  
[*address*]

\_\_\_\_\_  
[*date*]



**Section VIII – Bid forms, Price Schedule & Sample Forms**

**5. Bank Guarantee for Advance Payment**

To:  
The chief,  
Trishuli Hydropower Station,  
Nepal Electricity Authority,  
Trishuli, Nuwakot.

Gentlemen and/or Ladies:

In accordance with the payment provision included in the Contract, which amends Clause 10 of the General Conditions of Contract to provide for advance payment, *[name and address of Supplier]* (hereinafter called “the Supplier”) shall deposit with the Purchaser a bank guarantee to guarantee its proper and faithful performance under the said Clause of the Contract in an amount of *[amount of guarantee in figures and words]*.

We, the *[bank or financial institution]*, as instructed by the Supplier, agree unconditionally and irrevocably to guarantee as primary obligator and not as surety merely, the payment to the Purchaser on its first demand without whatsoever right of objection on our part and without its first claim to the Supplier, in the amount not exceeding *[amount of guarantee in figures and words]*.

We further agree that no change or addition to or other modification of the terms of the Contract to be performed there under or of any of the Contract documents which may be made between the Purchaser and the Supplier, shall in any way release us from any liability under this guarantee, and we hereby waive notice of any such change, addition, or modification.

The validity period of the guarantee shall be 30 days beyond the period scheduled for repayment of the advance payment and the guarantee shall remain valid and in full effect from the date of the advance payment under the Contract until the Purchaser receives full repayment of the same amount from the Supplier.

Yours truly,

Signature and seal of the Guarantors

---

*[name of bank or financial institution]*

---

*[address]*

---

*[date]*



**Section VIII – Bid forms, Price Schedule & Sample Forms**

**6. Manufacturer's Authorization Form**

Date :

To:

The chief,  
Trishuli Hydropower Station,  
Nepal Electricity Authority,  
Trishuli, Nuwakot.

WHEREAS *[name of the Manufacturer]* who are established and reputable manufacturers of *[name and/or description of the goods]* having factories at *[address of factory]*

We hereby authorize *[name and address of Agent]* solely to submit a Bid, and subsequently negotiate and sign the Contract with you against IFB No. *[reference of the Invitation to Bid]* for the above goods manufactured by us.

We hereby extend our full guarantee and warranty as per Clause 15 of the General Conditions of Contract for the goods offered for supply by the above firm against this Invitation for Bids.

---

*[Signature for and on behalf of Manufacturer]*

*Note:* This letter of authority should be on the letterhead of the Manufacturer and should be signed by a person competent and having the power of attorney to bind the Manufacturer. It should be included by the Bidder in its Bid.





## Section VIII – Bid forms, Price Schedule & Sample Forms

### 8. Data on Qualifications of Bidder

(Comprising Forms G-1 to G-10 to be accomplished by Bidder and Manufacturer as required)

Form: G-1

General Information on the Bidder

Name of the Bidder:

Name of Chief Executive Officer:

Name of the BIDDER's authorised representative in Nepal:

Office Address:

Telephone: Fax:

Is the Bidder himself the Repair Workshop of the GOODS?: Yes No

Is a copy of the company's registration included?: Yes No

Is the Bidder an agent or seller of another Repair Workshop?: Yes No

Principal manufacturer / Service provider of the GOODS:

Address of manufacturer:

Telephone: Fax:

Has authorization letter from the main service provider been included?: Yes No

Has the BIDDER's Organization Chart been included?: Yes No

No. of Administrative Staff: No. of technical staff: Yes No

No. of specialized Technicians: Availability of sales service Yes No

Does the Bidder maintain a permanent minimum workshop facility/machinery?: Yes No

\_\_\_\_\_ Signature and Stamp of the Bidder



**Section VIII – Bid forms, Price Schedule & Sample Forms**

**Form: G-2**

**Statement of Due Performance**

To.

Nepal Electricity Authority  
Generation Operation and Maintenance  
Trishuli Hydropower Station  
Trishuli, Nuwakot

Gentleman,

The Bidder hereby declares that, till date, no dispute has raised in any contract executed or under execution other than the cases herewith mentioned. All claims raised have been settled amicably between NEA and the bidder beside the cases listed here below. No civil or criminal case against the bidder has been raised or is currently being raised or being dealt with in court other than the cases here with listed.

List of disputes raised in other contracts:

Contract Employer Date of dispute Amount Remarks

.....

List of claims pending from other contracts:

Contract Employer Date of claim Amount Remarks

.....

List of civil criminal cases:

Contract Employer Date Court Case

.....

Signed and sealed this day ... .. of ... ..

.....

BIDDER's Name in Print and Signature



**Section VIII – Bid forms, Price Schedule & Sample Forms**

**Form: G-3 Records of Major Contract(s) Executed**

(To be accomplished by the manufacturer for the last three years)

Below, are listed major clients dealing with the Bidder in goods and services similar to the ones to be supplied under this Bid.

| Client name | location | Date of completion of contract | List of similar services supplied | remarks |
|-------------|----------|--------------------------------|-----------------------------------|---------|
|             |          |                                |                                   |         |
|             |          |                                |                                   |         |
|             |          |                                |                                   |         |
|             |          |                                |                                   |         |
|             |          |                                |                                   |         |

\_\_\_\_\_  
Signature and Stamp of the Bidder

- (1) The bidder is required to furnish complete postal address together with telephone and fax numbers of the client as an attachment to this Form.
- (2) Please provide the list of similar goods supplied specifying their ratings, sizes or major features. An attachment may be added if the space is not sufficient.



**Section VIII – Bid forms, Price Schedule & Sample Forms**

**Form: G-4**

**Records of Major Contract(s) on Hand**

(To be accomplished by the manufacturer)

Below, are listed major clients dealing with the Bidder in goods and services similar to the ones to be supplied under this Bid.

| Client name | location | Value of contract | Portion completed (in value) | Remaining portion (in value) |
|-------------|----------|-------------------|------------------------------|------------------------------|
|             |          |                   |                              |                              |
|             |          |                   |                              |                              |
|             |          |                   |                              |                              |
|             |          |                   |                              |                              |
|             |          |                   |                              |                              |

\_\_\_\_\_  
Signature and Stamp of the Bidder

- (1) The bidder is required to furnish complete postal address together with telephone and fax numbers of the client as an attachment to this Form.
- (2) Please provide the list of similar goods supplied specifying their ratings, sizes or major features. An attachment may be added if the space is not sufficient.



**Section VIII – Bid forms, Price Schedule & Sample Forms**

**Form: G-5**

**Bank Reference**

(To be completed by Bidder)

To.

Nepal Electricity Authority  
Generation Operation and Maintenance  
Trishuli Hydropower Station  
Trishuli, Nuwakot

Gentleman,

It is here by certify that ... .. (Name of Bidder) ... .. is known to us since ..... and he has been operating regularly in different business transactions with our bank. His commercial performance has been always acceptable to us and we are entirely satisfied with his overall conduct on business. On the basis of his assets and relation with us we are currently granting him a line of credit up to ...(specify the amount)..... According to our best knowledge he has never been involved in any suspension of payment irregularity either to Government to Non-Government Organization.

We are pleased to maintain relations with .....and we kindly recommend him to you for his sound financial background and practices.

Signed and sealed.

\_\_\_\_\_ Name of the Bank

\_\_\_\_\_ Signature and name of Bank's representative.



**Section VIII – Bid forms, Price Schedule & Sample Forms**

**Form: G-6**

**Statement of Non-involvement in Bankruptcy**

To.

Nepal Electricity Authority  
Generation Operation and Maintenance  
Trishuli Hydropower Station  
Trishuli, Nuwakot

Gentleman,

It is here by certify that ... .. (Name of Bidder) ... .. has never either himself of any of his direct associates or any of his administrators has been involved in any case of bankruptcy or suspension of payments.

Signed and sealed this day .....of .....

.....  
Bidder's Name in Print and Signature



**Section VIII – Bid forms, Price Schedule & Sample Forms**

**Form: G-7**

**Financial Performance**

(To be completed by Bidder)

|                           | 070/71 | 071/72 | 072/73 |
|---------------------------|--------|--------|--------|
| Total current assets      |        |        |        |
| Total current liabilities |        |        |        |
| Total assets              |        |        |        |
| Total Liabilities         |        |        |        |
| Working capital           |        |        |        |
| Annual Turnover           |        |        |        |

---

\_\_\_\_\_  
Signature and Stamp of Bidder

Audited Financial Statements for the above mentioned three years (counted about one and half year prior to the bid submission) shall be submitted.



**Section VIII – Bid forms, Price Schedule & Sample Forms**

**Form: G-8**

To be filled by bidder

**Manufacturing Experience**

(For this follow Section iii clause 18.1.b.2.i, ii & iii)

(To be filled up by manufacturer)

Product name: .....

First Year of manufacturing: .....

Quantity of products produced:(for last Fiveyears)

|  | year | year | year | year | year |
|--|------|------|------|------|------|
|  |      |      |      |      |      |
|  |      |      |      |      |      |

Manufactured under own development : Yes No

Manufactured under license from : .....

Manufactured collaboration with : .....

Other relevant information :.....

Has the Bidder R & D section Yes No

No. of staff in R & D section : ..... Level of education: .....

Has the manufacturer a quality assurance system in place? Yes No

Is the manufacturer certified or accredited by any organization? Yes No

Name the organization/s and type of accreditation/s or certification/s:

.....

.....

\_\_\_\_\_ Signature and Stamp of Manufacturer



## Section VIII – Bid forms, Price Schedule & Sample Forms

### Form: G-9

To be filled by bidder

| S No. | description  | NEA requirement  | Bidder's status |
|-------|--|--|-----------------|
| 1     | project experience   |  |                 |
| 1.1   | project experience   | At least 3 years   |                 |
| 1.2   | Users' Certificates  | The bidder shall submit minimum two customer letter/certificate/contract documents which confirms supply of turbine parts mentioned in the contract  |                 |
| 2     | Manufacturing experience   |  |                 |
| 2.1   | Manufacturing experience   | at least 3 years   |                 |
| 2.2   | Users' Certificates  | at least form 2 users for 2 times the bid qty  |                 |
| 2.3   | Satisfactory operation of GOODS for at least 1 year  | 0.5 times bid quantity   |                 |
| 3     | Financial status (to be filled by bidder)  |  |                 |
| 3.1   | a) for the bidder which is not a joint venture average annual turnover of the bidder over the last 3 years<br>b) for the JV Bidder annual turnover for each year of the lead partner over last 3 years<br>annual turnover for each year of the other partner over last 3 years | at least NRs.15 lakhs<br><br>at least 40%<br><br>at least 25%  |                 |
| 3.2   | a) for the bidder which is not a JV bidder working capital in the last fiscal year<br>b) for the JV Bidder working capital in the last fiscal year for the lead partner<br>working capital in the last fiscal year for the other partner                                       | at least NRs. 10 lakhs<br><br>at least 40%<br><br>at least 25%   |                 |
| 3.3   | Audited balance sheet as specified in form G7 submitted?   | to be submitted  |                 |
| 4     | Miscellaneous  |  |                 |
| 4.1   | power of attorney  | needed   |                 |
| 4.2   | No. of JV partners   | not more than 3  |                 |
| 4.3   | Legal registration of firm of the bidder/s   | needed   |                 |
| 4.4   | submission of audited financial statement  | for last 3 years   |                 |
| 4.5   | valid quality ISO certificate  | needed   |                 |
| 4.6   | end user's certificate for similar type of job   | at least 2   |                 |
| 4.7   | Blacklisting of the Bidder/s   | No   |                 |
| 4.8   | Facility of repairing workshop   | compressor and blasting equipments<br>suitable welding machine, grinding machine, polishing machine and other facilities for repair work<br>NDT facilities<br>balancing test facilities<br>horizontal and vertical lathe of adequate capacity<br>D/G set<br>Drilling machine |                 |

**Section VIII – Bid forms, Price Schedule & Sample Forms**

**Form G-10**

**Joint Venture Data**

(If the Bidder is Joint Venture partner)

S. No. Name of the JV partner Share of liability Contact address

- 1.
- 2.
- 3.

Name of the lead partner

Each JV partner shall fill up the necessary G forms individually.



**Section VIII – Bid forms, Price Schedule & Sample Forms**

**G-11**

**9. Declaration Letter**

Date :

To:

**The chief,  
Trishuli Hydropower Station,  
Nepal Electricity Authority,  
Trishuli, Nuwakot.**

It is hereby declared on behalf of **[name of the bidder]** that we are not ineligible for the procurement proceedings, do not have any conflict of self into procurement proceedings and we have not been punished by authority in the related profession of the business till date

---

*[Signature for and on behalf of Manufacturer]*

**Note:** This letter of declaration should be on the letterhead of the Manufacturer and should be signed by a person competent and having the power of attorney to bind the Manufacturer.



## Section VIII – Bid forms, Price Schedule & Sample Forms

### Checklist: To be filled by bidder

| S. No | Description  | Issued to/by (as applicable) | Date of Issue | No. of Pages |
|-------|--|------------------------------|---------------|--------------|
| 1     | Notarized Power of Attorney from the Company to sign on Company's behalf (For Single Bidder) |                              |               |              |
| 2     | Joint Venture Agreement: <i>If any</i>   |                              |               |              |
| 3     | Notarized Power of Attorney to sign the Bid on Company's behalf (Each Partner in case of JV) |                              |               |              |
| 4     | Notarized Power of Attorney to sign the Bid (On Behalf of JV)                                |                              |               |              |
| 5     | Registration Certificate of the Bidder (and each partners in case of JV)                     |                              |               |              |
| 6     | Bid Bond   |                              |               |              |
| 7     | Price Schedule   |                              |               |              |
| 8     | Bid Forms  |                              |               |              |
| 9     | Qualification Forms  |                              |               |              |
| 10    | Complete Certified Audited Report of the Bidder (and each partner in case of JV)             | First Year                   |               |              |
|       |  | Second Year                  |               |              |
|       |  | Last Year                    |               |              |
| 11    | Bidder s letter of Experience  | 1                            |               |              |
|       |  | 2                            |               |              |
|       |  | 3                            |               |              |
| 12    | Manufacturer s Authorization s   | 1                            |               |              |
|       |  | 2                            |               |              |
| 13    | Power of Attorney for signing the Bid Document & made the declaration                        |                              |               |              |
| 14    | Business License of Manufacturers  | 1                            |               |              |
|       |  | 2                            |               |              |
| 15    | User Certificate s (Manufacturer)  | 1                            |               |              |
|       |  | 2                            |               |              |
| 16    | ISO Certificates   | 1                            |               |              |
|       |  | 2                            |               |              |
| 17    | Type Test Reports Of required as per specification)  | 1                            |               |              |
|       |  | 2                            |               |              |
| 18    | Technical Data Sheet   | 1                            |               |              |
|       |  | 2                            |               |              |
| 19    | Other Certification (as per requirements)  | 1                            |               |              |
|       |  | 2                            |               |              |