

Nepal Electricity Authority
(Undertaking Government of Nepal)
Generation Directorate
Medium Generation Operation and Maintenance Department
Sundarijal Hydro Power Station
Sundarijal, Kathmandu.

Sealed Quotation
SHPS /RW-01/2074/075

Quotation Bid Document
for

**Repair and Maintenance Supply Delivery of Turbine Shaft Thrust Oil Bearing -
System.**

2075 Falgun



Table of Contents

| | |
|--|-----------|
| Section I. Invitation for Sealed Quotation..... | 2 |
| Section II. Instructions to Bidders | 3 |
| Section III. Conditions of Contract... .. | 6 |
| Section IV. Schedule of Requirement | 10 |
| Section V. Technical Specification | 11 |
| Section VI. Required Forms | 12 |
| 1. Quotation and Price Schedules | 12 |
| 2. Bid Security..... | 14 |
| 3. Form of Agreement..... | 15 |
| 4. Performance Security..... | 16 |
| 5. Bank Guarantee for Advance Payment..... | 17 |



Section I. Invitation for Sealed Quotation

Name of the Purchaser: Nepal Electricity Authority
Medium Generation Operation /Maintenance Department For
Sundarijal Hydro Power Station
Address of the Purchaser: Sundarijal, Kathmandu.
Nepal
Tel: 01-4800806
Fax:.....

Invitation for Sealed Quotation

Sealed Quotation No: SHPS/RW-01/2074/075

Date of first Publication: 2074/11/16

1. Nepal Electricity Authority, Sundarijal Hydro Power Station invites sealed quotations from registered firm for the Repair and Maintenance Supply Delivery of Turbine Shaft Thrust Oil Bearing for SHPS, Sundarijal, Kathmandu.
2. Interested eligible Bidders may obtain further information and inspect the Sealed quotation Forms at the Purchaser of
Nepal Electricity Authority
Medium Generation Operation /Maintenance Department.
Durbarmarg, Kathmandu.
Nepal
Tel: 014153081
Fax: 014153081
3. Sealed Quotation Forms may be purchased by eligible Bidders on the submission of a written application and upon payment of a non-refundable fee of **NRs.1000.00** upto **15th day from the date of first publication of notice.**
4. Sealed Quotations must be submitted to the above Purchaser on or before **12:00 noon (Local Time)** upto **16th day from the date of first publication of notice.** Quotation received after this deadline shall not be accepted.
5. Quotations must be valid for a period of **45 days** after opening of Sealed quotations and must be accompanied by Cash Security or Bank Guarantee, amounting to a **minimum of NRs. 13,000.00** which shall be **valid for 75 days** after opening of the Sealed Quotations.
6. If bidder wishes to submit the Cash Security, the cash should be deposited in Deposit Account No **1206101001012524 Nepal Rastra Bank** at Thapathali, Kathmandu and submit the receipt of the deposited amount of cash along with the Sealed Quotation.
7. Sealed Quotation shall be opened in the presence of Bidders' representatives who choose to attend at **2:00 PM on 16th day of the first date of publication of notice** at the Purchaser of
Nepal Electricity Authority
Medium Generation Operation /Maintenance Department
Durbarmarg, Kathmandu.
Nepal
Tel: **014153081**
Fax: **014153081**

If the last date of purchasing, submission and opening falls on a government holiday then the next working day shall be considered the last day.

8. Purchaser reserves the right to accept or reject, wholly or partly any or all the Sealed Quotations without assigning any reason, whatsoever.



Section II. Instructions to Bidder

- 1. Scope of Works**

9. Purchaser stated in the Invitation for Quotation invites bids for the Repair and Maintenance Supply Delivery of Turbine Shaft Thrust Oil Bearing-2 Set of the goods and related services as detailed in attached specifications, drawings and the bill of quantities provided herein. .
- 2. Eligible Bidder**

This Invitation for Bids is open to all registered Bidders with qualifications as described below:

 - a) Up to date Firm/Company Registration Certificate
 - b) VAT and PAN Registration Certificates
 - c) Tax Clearance Certificate
 - d) Power of Attorney
 - e) Other documents as needed
- 3. One Bid per Bidder**

Each Bidder shall submit only one quotation, A Bidder who submits more than one quotation shall cause all the quotations with the Bidder's participation to be disqualified.
- 4. Content of Quotation Form**

The Quotation Form comprise the documents listed below:

 1. Invitation for Sealed Quotations
 2. Instructions to Bidders
 3. General Conditions of Contract (GCC)
 4. Form of Agreement
 5. Required firms.
 6. Technical Specification
- 5. Clarification**

A prospective Bidder may obtain clarification on the Quotation Form from the Purchaser stated in Invitation for Quotation.
- 6. Language of Quotation**

All documents relating to the Quotation shall be in English or in Nepali.
- 7. Documents Comprising Quotation**

The Quotation by the Bidder shall comprise the following:

 - a. Quotation and Price Schedules
 - b. Bid Security
 - c. Schedule of Requirements
 - d. Technical Specifications
- 8. Quotation Prices**

The Bidder shall indicate on the appropriate Price Schedule the unit prices (where applicable) and total price of the job under the contract.

All duties, taxes and other levies payable by the Bidder under the contract shall be included in the rates, prices and total Bid Price submitted by the Bidder.

Price quoted by the Bidder shall remain fixed and valid until completion of the Contract Performance and will not be subject to variation in any account.

- 9. Quotation Validity** The Quotation shall remain valid for the period of 45 days after opening of the quotation.
- 10. Quotation Security** The Bidder shall furnish a Security in Nepali Rupees in the amount NRs. 20,000.00. The Bid Security shall remain valid for a period of 75 days after opening of the quotation.
The Security shall be in the form of cash voucher deposited in the Bank Account of the Employer specified in the notice for "Invitation for Quotation" or a bank guarantee from a bank acceptable to the Employer.
- 11. Format and Signing of Quotations** The Quotation shall be typed or written in indelible ink and shall be signed by an authorized person. Any entries or amendments including alternations, additions or corrections made shall be initialled by the same authorized person.
- 12. Sealing and Marking of Quotations** The Bidder shall submit his Quotation in sealed envelopes. The envelope shall be addressed to Purchaser specified in the Invitation for Quotation and shall bear the name and identification number of the quotation.
- 13. Deadline for Submission of Quotations** Quotations shall be delivered to Purchaser at the address no later than the time and date specified in the Invitation for Quotation.
- 14. Late Quotation** Any Quotation received by Purchaser after the deadline shall not be accepted and shall be returned unopened to the Bidder upon request.
- 15. Modification And Withdrawal** Quotations once submitted shall not be withdrawn or modified.
- 16. Bid Opening** Purchaser shall open the Quotations in the presence of the Bidders' representatives who choose to attend at the time and in the place as specified in the Invitation for Quotation.
Purchaser shall prepare and provide minutes of the opening including the information disclosed to those present.
- 17. Process to be Confidential** Information relating to the examination, evaluation and comparison of Quotations and recommendations for the award of a contract shall not be disclosed to Bidders or any other persons not officially concerned with such process until the award to the successful Bidder has been announced. Any efforts by the Bidder to influence Purchaser in the Quotation evaluation, comparison or contract award decisions may result in rejection of Bidder's quotation.
- 18. Examination of Quotations** Prior to the detailed evaluation of Quotations, Purchaser shall determine whether each Quotation (a) meets the eligibility criteria defined in Clause 2; (b) has been properly signed; (c) is accompanied by the required securities; and (d) is substantially responsive to the requirements of the Bidding documents.

- 19. Evaluation and Comparison of Quotations**
- 19.1 In evaluating the Quotations, Purchaser shall determine for each Quotation the evaluated Bid Price by adjusting any corrections for errors. Quotations shall be checked by Purchaser for any arithmetic errors. Errors shall be corrected by Purchaser as follows:
- a. where there is a discrepancy between the amounts in figures and in words, the amount in words shall govern; and
 - b. where there is a discrepancy between the unit rate and the line item total resulting from multiplying the unit rate by the quantity, the unit rate as quoted shall govern
- 19.2 If the Bidder does not accept the corrected amount, the Quotation shall be rejected and the Security pursuant to Clause 10 may be forfeited.
- 20. Award of Contract**
- Purchaser shall decide the award of the contract, within 15 days of the opening of the quotation, to the Bidder whose Quotation is within the approved estimate and who has offered the lowest evaluated Bid Price, provided that such Bidder has been determined to be eligible in accordance with the provisions of Clauses 2.
- 21. Right to Accept or Reject**
- Purchaser reserves the right to accept or reject any Quotation or to cancel the bidding process and reject all Quotations, at any time prior to the award of the contract, without assigning any reasons whatsoever and without thereby incurring any liability to the affected Bidder or Bidders.
- 22. Notification of Award and Signing of Agreement**
- 22.1 The Bidder whose Quotation is accepted and all other participating bidders shall be notified of the award by Purchaser. Within 7 days of receipt of the notification, the successful Bidder shall deliver the Performance Security pursuant to Clause 23 and sign the Agreement.
- 22.3 Inability of the Bidder to make an Agreement within the above stated period shall result in cancellation of the Contract Award and forfeiture of the Bidder's Security, upon which the Contract shall then be awarded to the next successive successful Bidder.
- 23. Performance Security**
- The successful Bidder shall deliver to Purchaser a Performance Security in cash or Bank Guarantee acceptable to Purchaser equivalent to 5% of the Quotation amount.

Section III. Conditions of Contract

- 1. Definitions**
- 1.1 In this contract, the following terms shall be interpreted as indicated:
- a. "The Contract" means the agreement entered into between Purchaser and the Bidder, as recorded in the Contract Form Signed by the parties, including all attachments and appendices thereto and all documents incorporated by reference therein;
 - b. "The Contract Price" means the price payable to the Firm under the contract for the full and proper performance of its contractual obligation;
 - c. "The Goods" means Equipment and related Accessories and spare-parts or any other materials which the Firm is required to supply to Purchaser under the contract;
 - d. "Services" means services ancillary to the supply of the goods such as transportation and insurance including the installation, commissioning and the operational and maintenance training of the installed equipment.
 - e. "Purchaser" means the procuring entity taking the services Medium Generation Operation and Maintenance Department for Sundarijal Hydropower Station.
 - f. "The Firm" means the organization providing the services under this contract.
- 2. Technical Specification**
- 2.1 The service under this contract shall confirm to the standards mentioned in the Technical Specification.
- 3. Patent Right**
- 3.1 The Firm shall indemnify Purchaser against all third-party claims of infringement of patent, trademark or industrial design rights arising from use of goods or any part thereof in Purchaser's country.
- 4. Performance Security**
- 4.1 Within seven days (7) of receipt of award of contract from Purchaser the successful Bidder shall furnish the performance security in accordance with the Sub - Clause 4.3 of the Conditions of Contract in the Performance Security Form provided in the Bidding Documents.
- 4.2 Failure of the successful Firm to comply with the requirement of Sub - clause 4.1 shall constitute sufficient grounds for the annulment of the award and forfeiture of the bid security, in which event Purchaser may make the award to the next lowest Firm or call for new sealed quotations.
- 4.3 The performance security will be as follows:
- a. The amount of performance security as a percentage of the contract price shall be five (5) percent of the Sealed Quotation Price in the currency of the Sealed Quotation price.
- 4.4 The validity of Performance Security shall be one (1) year after the final installation and commissioning of the Goods and the issue of final acceptance certificate to the Bidders. The Firm shall promptly extend the validity suitably to cover agreed extension of the warranty period of the supplied goods.
- 4.5 The performance security shall be released within 28 days of completion of warranty period and upon submission of claim by the Firm.

-
5. **Inspection and Tests** 5.1 Purchaser or its Representatives shall have the right to inspect and/or test the goods to confirm their conformity to the Technical Specification and the quality of performance after the completion of job to Purchaser's premises.
6. **Warranty** 6.1 The Firm warrants that the service under the contract shall fully comply with the specification laid down in the contract.
- 6.2 The warranty shall remain valid for one year after the completion of service indicated in the contract, and accepted by Purchaser after installation and commissioning of equipment by the Firm.
- 6.3 Purchaser shall promptly notify the Firm in writing of any claims arising under this warranty.
- 6.4 Upon receipt of such notice, the Firm shall, with all reasonable speed, repeat the job without cost to Purchaser. The Firm will be entitled to repeat, at its own risk and cost.
7. **Payment** 7.1 Payment shall be made in the currency in which the contract price has been stated in the Firm's Sealed Quotation.
- 7.2 Payment to the firm within Nepal shall be made in Nepali Rupees after the completion of job.
8. **Prices** 8.1 Prices charged by the Firm of the total job under the contract shall not vary from the prices quoted by the Firm in its sealed quotation.
19. **Changed Order** 9.1 Where Purchaser desires to make changes in **Schedule of Requirement**, it shall not exceed more than 15 percent.
10. **Liquidated Damages** 10.1 If the Firm fails to provide the service within the time period specified in the contract, Purchaser shall, without prejudice to its other remedies under the contract, deduct from the contract price, as liquidated damages, a sum equivalent to 0.05 percent of the contract price of delayed goods for each day of delay until actual delivery, up to a maximum deduction of 10 percent of the delayed goods' contract price. Once the maximum is reached, Purchaser may consider termination of the contract.
11. **Resolution of Disputes** 11.1 If any dispute or difference of any kind whatsoever shall arise between Purchaser and the Firm in connection with or arising out of the Contract, the parties shall make every effort to resolve amicably such dispute or difference by mutual consultation.
- 11.2 If, after thirty (30) days, the parties have failed to resolve their dispute or difference by such mutual consultation, then either Purchaser or Firm may give notice to the other party of its intention to commence arbitration, as hereinafter provided, as to the matter in dispute, and no arbitration in respect of this matter may be commenced unless such notice is given.
- 11.2.1 Any dispute or difference in respect of such a notice of intention to commence arbitration has been given in accordance with this Clause shall be finally settled by arbitration. Arbitration may be commenced prior to or after completion of job under the Contract.
- 11.2.2 Arbitration proceedings shall be conducted in accordance with the rules of Nepal Council of Arbitration (NEPCA).

-
- 11.3 Notwithstanding any reference to arbitration herein,
- a. the parties shall continue to perform their respective obligations under the Contract unless they otherwise agree; and
 - b. Purchaser shall pay the Firm any monies due the Firm.
- 12. Governing Language** 12.1 The Governing Language shall be: Nepali or English
- 13. Applicable Law** 13.1 The applicable law shall be Laws of Nepal.
- 14. Notices** 14.1 Purchaser address for notice purposes:
Nepal Electricity Authority
Medium Generation Operation and Maintenance Department.
Durbarmag, Kathmandu.
Nepal
Tel: 014153081
Fax: 014153081
- 14.2 Firm's address for notice purposes:
- 15. Taxes and Duties** 15.1 The Firm shall be entirely responsible for all taxes, duties, licence fees and other such levies imposed by the GON.
- 16. Conduct of Bidders** 16.1 The Firm shall be responsible to fulfil his obligations as per the requirement of the Contract Agreement, Bidding documents, GoN's Procurement Act and Regulations.
- 16.2 The Firm shall not carry out or cause to carryout the following acts with an intention to influence the implementation of the procurement process or the procurement agreement :
- a. give or propose improper inducement directly or indirectly,
 - b. distortion or misrepresentation of facts
 - c. engaging or being involved in corrupt or fraudulent practice
 - d. interference in participation of other prospective bidders.
 - e. coercion or threatening directly or indirectly to impair or harm, any party or the property of the party involved in the procurement proceedings,
 - f. collusive practice among bidders before or after submission of bids for distribution of works among bidders or fixing artificial/uncompetitive bid price with an intention to deprive Purchaser the benefit of open competitive bid price..
 - g. contacting Purchaser with an intention to influence Purchaser with regards to the bid or interference of any kind in examination and evaluation of the bids during the period after opening of bids up to the notification of award of contract
- 17. Blacklisting Firm** 17.1 Without prejudice to any right of Purchaser under this Contract, the GoN, Public Procurement and Monitoring Purchaser(PPMO) may blacklist a Firm for his conduct up to three years on the following grounds and seriousness of the act committed by the Firm:
- a. if it is proved that the Firm committed acts pursuant to the Sub - clause 16.2,
 - b. if the Firm fails to sign an agreement pursuant to ITB Clause 22,
 - c. if it is proved later that the Firm had committed substantial

-
- defect in implementation of the contract or had not substantially fulfilled his obligations under the contract or the completed work is not of the specified quality as per the contract ,
- d. if convicted by a court of law in a criminal offence which disqualifies the Firm from participating in the contract.

17.2 A Firm declared blacklisted and ineligible by the GON shall be ineligible to bid for a contract during the period of time determined by PPMO.

Section – IV Schedule of Requirement

NEPAL ELECTRICITY AUTHORITY Medium Generation Operation & Maintenance

Sundarijal Hydro Power Station, Sundarijal, Kathmandu Nepal

SEALED QUOTATION NO.: SHPS /RW-01/2074/075

Delivery Schedule

For

**Repair and Maintenance Supply and Delivery of Turbine Shaft Thrust Oil Bearing
Set-2**

1. Delivery Schedule Required By NEA

The complete delivery of the Goods/Services must be made at NEA, Sundarijal Hydro Power Station, Sundarijal, Kathmandu Nepal within the delivery time as specified below from the date of issue work order.

(a) Delivery Time of NEA, Sundarijal Hydro Power Station:- 45 Day from the date of issue of work order.

2. Delivery Schedule to be filled by Bidder :

(a) Delivery Time of Bidder: - *[Insert the delivery time]* days from the date of issue of work order.

Signature of Bidder:

Company Seal:

Name:

Address :



Section V Technical Specification

| Items | Name of the parts | Type and Specification |
|-------|--|---|
| 1 | Power House, Repair and Maintenance of Turbine Shaft Thrust Oil Bearing - System. | |
| 1.1 | Repair & Maintenance Supply Delivery of Turbine Shaft Thrust Oil Bearing Upper and Lower Set (One) -1.with Transportation. | The Lead White Metal should be poured on Bearing surface. The bidders are informed to verifying actual dimensions of Bearing at the Plant before final machining. |

Drawing and pictures of Thrust Bearing

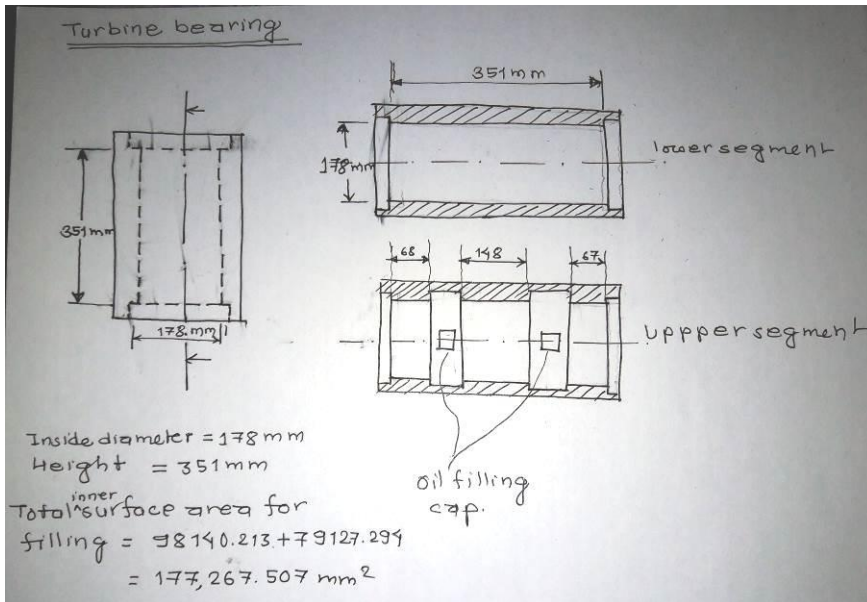

Section VI. Required Forms

1. Quotation and Price Schedules

Date:

To: Nepal Electricity Authority
Medium Generation Operation and Maintenance Department.
Durbarmag, Kathmandu

Tel: 014153081

Fax: 014153081

Gentlemen and/or Ladies:

Having examined the Sealed Quotation (SQ) documents, we the undersigned, offer to **Purchase the** of Repair and Maintenance of Turbine Shaft Thrust Oil Bearing Set-2 in conformity with the said SQ documents for the sum of or such other sums as may be ascertained in accordance with the Schedule of Prices attached herewith and made part of this SQ.

We undertake, if our SQ is accepted, to deliver the goods in accordance with the delivery schedule specified in the Schedule of Requirements.

If our SQ is accepted, we will obtain the guarantee of a bank in a sum equivalent to Five (5) percent of the Contract Price for the due performance of the Contract, in the form prescribed by Purchaser.

We agree to abide by this SQ for a Period of **45** days from the date fixed for SQ opening it shall remain binding upon us and may be accepted at any time before the expiration of that period.

Until a formal Contract is prepared and executed, this SQ, together with your written acceptance thereof and your notification of award, shall constitute a binding Contract between us.

We understand that you are not bound to accept the lowest or any SQ you may receive.

Dated this _____ day of _____ 20_____.

[signature]

[in the capacity of]

Duly authorized to sign SQ for and on behalf of _____



NEPAL ELECTRICITY AUTHORITY
SUNDARIJAL HYDROPOWER STATION
Power House, Bearing Repair works.

BoQ

| Items | Name of the parts | Type and Specification | Unit | Quantity | Unit Rate | Total Amount | Remarks |
|---------------------------------|--|------------------------------|------|----------|-----------|--------------|---------|
| 1 | Power House, Repair and Maintenance of Turbine Shaft Thrust Oil Bearing - System | | | | | | |
| 1.1 | Repair of Turbine Shaft Thrust Oil Bearing Upper and Lower Set (One)- 1.with Transportation. | As Per Technical Requirement | Set | 2 | | | |
| Sub-Total (NRs) | | | | | | | |
| Vat @ 13% (NRs) | | | | | | | |
| GRAND TOTAL AMOUNT (NRs) | | | | | | | |

Amount in Words:



[Handwritten Signature]

2. Bid Security

Date :

To: Nepal Electricity Authority
Medium Generation Operation and Maintenance Department.
Durbarmag, Kathmandu

Tel: 014153081

Fax: 014153081

Whereas, (hereinafter called “the Bidder”) has submitted his Sealed Quotation (SQ) dated for the **Procurement of Repair and Maintenance Supply & Delivery of Turbine Shaft Thrust Oil Bearing Set -2** (hereinafter called “the Sealed Quotation”). KNOW ALL PEOPLE by these presents that WE of Nepal having our registered Purchaser at (hereinafter called “the Bank”) are bound unto **Panauti Hydro Power Station** (hereinafter called “Purchaser”) in the sum of **NRs**..... for which payment well and truly to be made to the said Purchaser, the Bank binds itself, its successors, and assigns by these presents. Sealed with the Common Seal of the said Bank this _____ day of _____ 20_____.

THE CONDITIONS of this obligation are:

- (1) If, the Bidder withdraws its SQ during the period of bid validity specified by the Bidder on the SQ Form; or
- (2) If the Bidder having been notified of the acceptance of its SQ by Purchaser during the period of bid validity:
 - (a) fails or refuses to execute the Contract Form, if required; or
 - (b) fails or refuses to furnish the performance security, in accordance with the Instruction to Bidders;

we undertake to pay to Purchaser up to the above amount upon receipt of its first written demand, without Purchaser’s having to substantiate its demand, provided that in its demand Purchaser will note that the amount claimed by it is due to it owing to the occurrence of one or both of the two conditions, specifying the occurred condition or conditions.

This guarantee will remain in force up to ninety (75) days from the date of opening of the Sealed Quotation, and any demand in respect thereof should reach the Bank not later than the above date.

[signature of the bank]

[common seal of the bank]



3. Form of Agreement

THIS AGREEMENT made the ____ day of _____ 20____ between Nepal Electricity Authority Medium Generation Operation and Maintenance Department, Kathmandu (hereinafter called “Purchaser”) of the one part and of (hereinafter called “the Firm”) of the other part: WHEREAS Purchaser invited Sealed Quotation for the job, viz., **Procurement of Repair and Maintenance of Turbine Shaft Thrust Oil Bearing Set. -2** and has accepted a SQ by the Firm for the supply of those goods and services in the sum of (hereinafter called “the Contract Price”).

NOW THIS AGREEMENT WITNESSETH AS FOLLOWS:

1. In this Agreement words and expressions shall have the same meanings as are respectively assigned to them in the Conditions of Contract referred to.
2. The following documents shall be deemed to form and be read and construed as part of this Agreement, viz.:
 - a. Quotation Form and the Price Schedule submitted by the Firm;
 - b. The Schedule of Requirements;
 - c. The Conditions of Contract; and
 - d. Purchaser’s Notification of Award.
3. In consideration of the payments to be made by Purchaser to the Firm as hereinafter mentioned, the Firm hereby covenants with Purchaser to provide the goods and services and to remedy defects therein in conformity in all respects with the provisions of the Contract.
4. Purchaser hereby covenants to pay the Firm in consideration of the provision of the goods and services and the remedying of defects therein, the Contract Price or such other sum as may become payable under the provisions of the contract at the times and in the manner prescribed by the Contract.

IN WITNESS whereof the parties hereto have caused this Agreement to be executed in accordance with their respective laws the day and year first above written.

On behalf of Purchaser

On behalf of the Firm

Name:

Name:

Designation:

Designation:

Sign:

Sign:

Seal:

Seal:



4. Performance Security

Date :

To: Nepal Electricity Authority
Medium Generation Operation and Maintenance Department.
Durbargmarg, Kathmandu.
Nepal
Tel: 014153081
Fax: 014153081

WHEREAS (hereinafter called "the Firm") has undertaken, in pursuance of Contract No. **SHPS/RW-01/2074/075** dated _____ 20____ to **Purchase the** Repair and Maintenance Supply Delivery of Turbine Shaft Thrust Oil Bearing Set. -2 (hereinafter called "the Contract").

AND WHEREAS it has been stipulated by you in the said Contract that the Firm shall furnish you with a bank guarantee by a reputable bank for the sum specified therein as security for compliance with the Firm's performance obligations in accordance with the Contract.

AND WHEREAS we have agreed to give the Firm a guarantee:

THEREFORE WE hereby affirm that we are Guarantors and responsible to you, on behalf of the Firm, up to a total of, and we undertake to pay you, upon your first written demand declaring the Firm to be in default under the Contract and without cavil or argument, any sum or sums within the limits of [amount of guarantee] as aforesaid, without your needing to prove or to show grounds or reasons for your demand or the sum specified therein.

This guarantee is valid until the _____ day of _____ 20_____.

Signature and seal of the Guarantors

Name:.....

Address:.....

Date:.....



5. Bank Guarantee for Advance Payment

To: Nepal Electricity Authority
Medium Generation Operation and Maintenance Department.
Durbargmarg, Kathmandu.
Nepal
Tel: 014153081
Fax: 014153081

SHPS/ RW-01/2074/075

Gentlemen and/or Ladies:

In accordance with the payment provision included in the Contract, which amends Clause 10 of the General Conditions of Contract to provide for advance payment,
..... (hereinafter called "the Firm") shall deposit with Purchaser a bank guarantee to guarantee its proper and faithful performance under the said Clause of the Contract in an amount of

We,, as instructed by the Firm, agree unconditionally and irrevocably to guarantee as primary obligator and not as surety merely, the payment to Purchaser on its first demand without whatsoever right of objection on our part and without its first claim to the Firm, in the amount not exceeding

We further agree that no change or addition to or other modification of the terms of the Contract to be performed there under or of any of the Contract documents which may be made between Purchaser and the Firm, shall in any way release us from any liability under this guarantee, and we hereby waive notice of any such change, addition, or modification.

The validity period of the guarantee shall be 30 days beyond the period scheduled for repayment of the advance payment and the guarantee shall remain valid and in full effect from the date of the advance payment under the Contract until Purchaser receives full repayment of the same amount from the Firm.

Yours truly,

Signature and seal of the Guarantors

Name:

Address:

Date

