

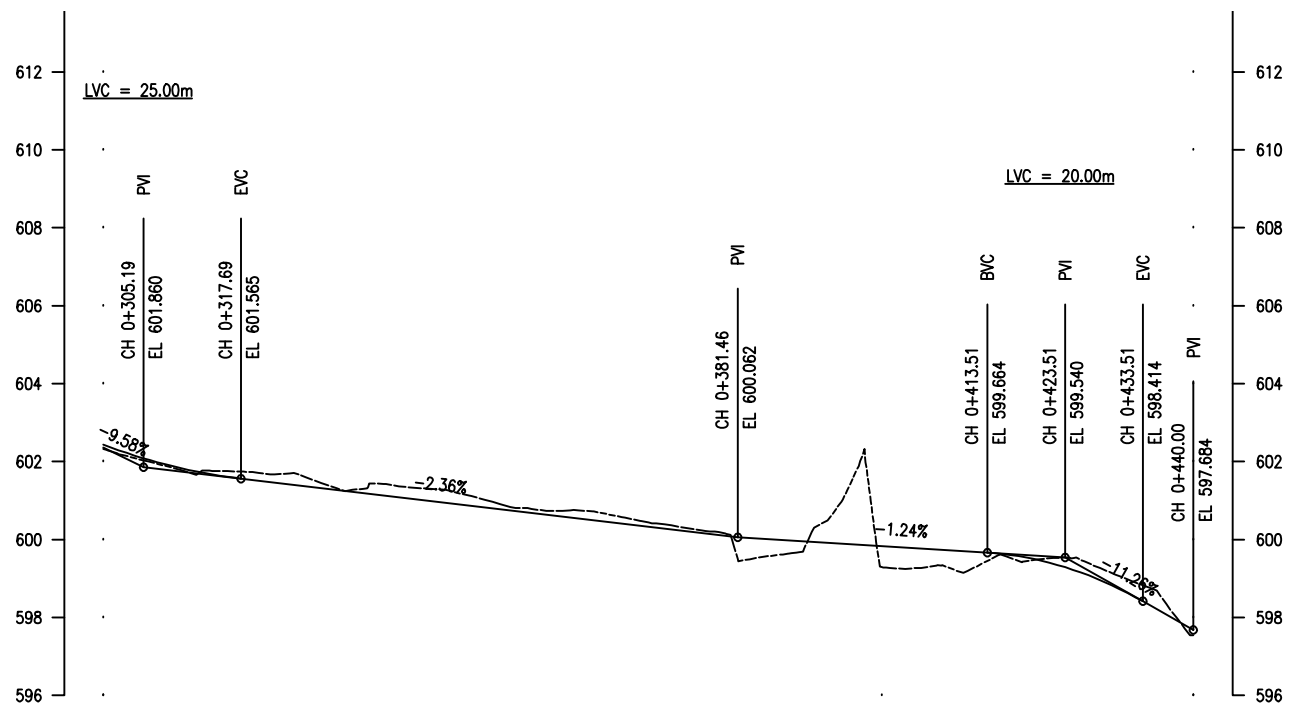

PLAN & PROFILE

Ghatta-UttarGaya

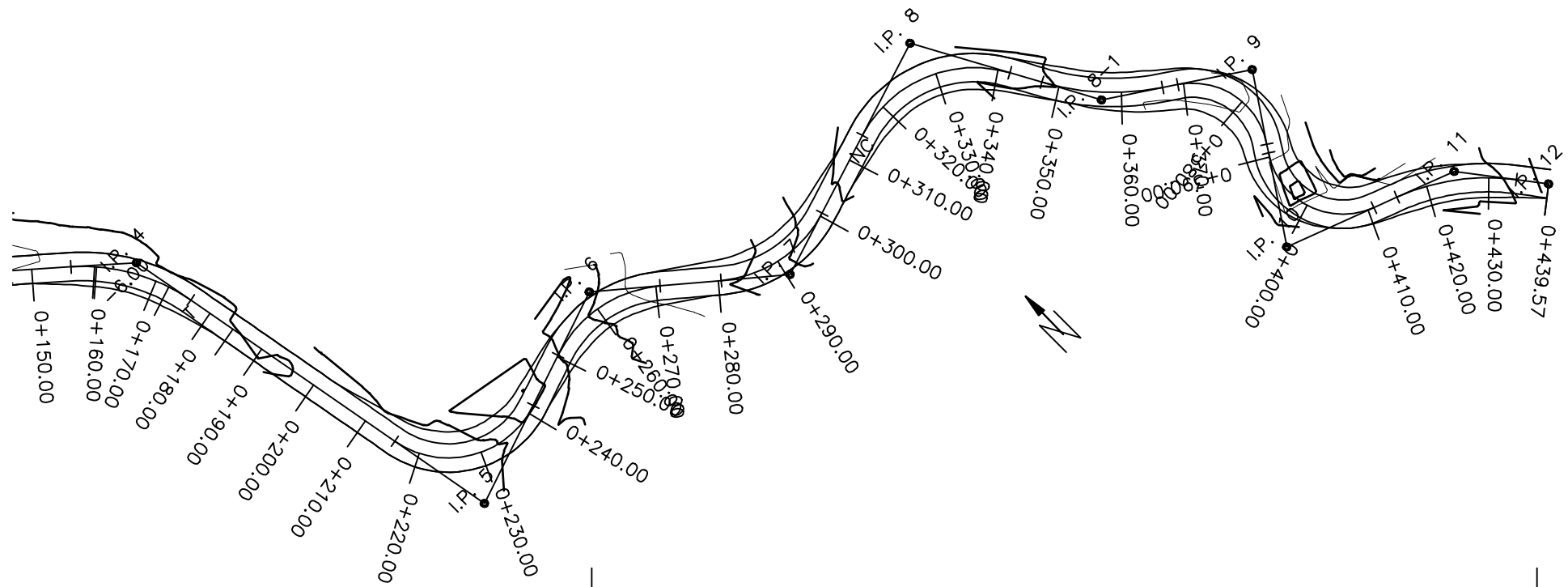

DESIGN LEVEL (m)	602.434	601.832	601.511	601.275	601.039	600.804	600.568	600.332	600.096	599.956	599.832	599.708	599.478	598.779	597.684
EXISTING LEVEL (m)	602.331	601.784	601.711	601.312	601.326	600.967	600.745	600.438	600.149	599.761	599.292	599.166	599.487	599.100	597.544
CHAINAGE (km)	0+300.00	0+310.00	0+320.00	0+330.00	0+340.00	0+350.00	0+360.00	0+370.00	0+380.00	0+390.00	0+400.00	0+410.00	0+420.00	0+430.00	0+440.00
HORIZONTAL ALIGNMENT	RIGHT	IP-08			IP-09				IP-11			IP-12			
	LEFT	R=20.00	R=20.00	R=40.00	R=12.00	R=12.00	R=35.00	R=0.00							

NEPAL ELECTRICITY AUTHORITY
UPPER TRISHULI 3A HYDRO ELECTRIC PROJECT

UPGRADING EXISTING ROAD
TRISHULI COLONY TO CHAMPANI
(GHATTA-UTTARGAYA)

DESIGNED BY :
DRAWN BY :
CHECKED BY :
APPROVED BY :

SCALE

PLAN & PROFILE
CH 0+300.00-0+440.00

DATE:
DRG NO : 1
SHEET NO : 2



CROSS-SECTION

Ghatta-UttarGaya

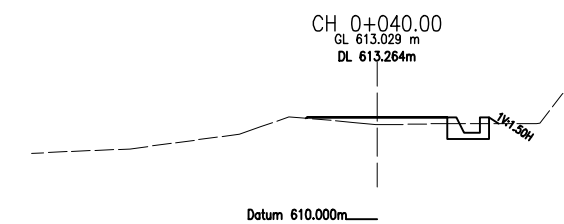
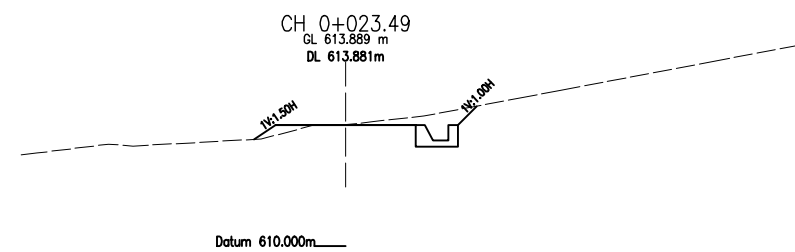
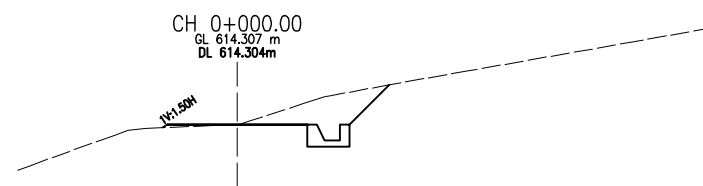
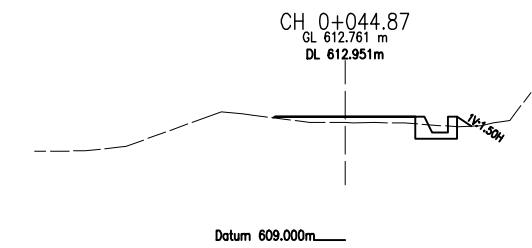
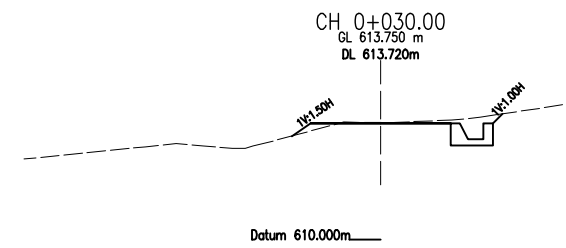
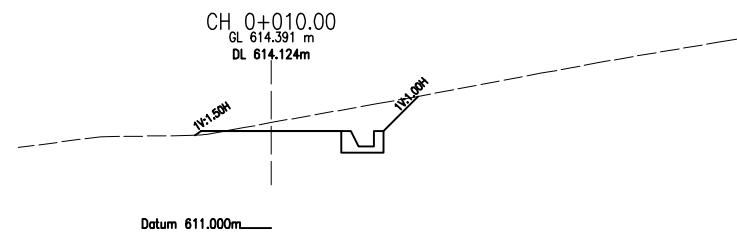
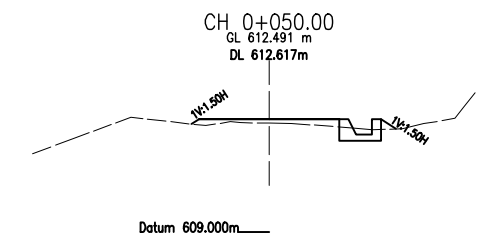
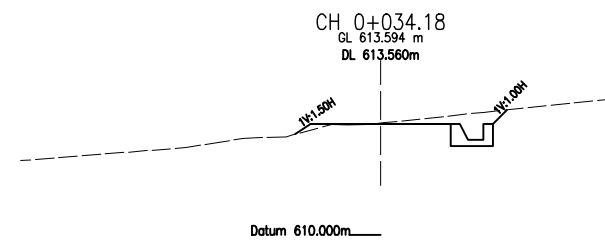
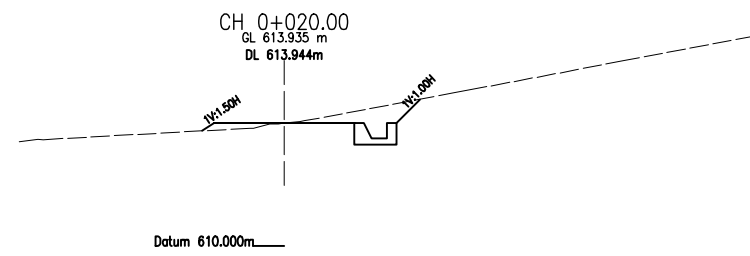

NEPAL ELECTRICITY AUTHORITY
UPPER TRISHULI 3A HYDRO ELECTRIC PROJECT

UPGRADING EXISTING ROAD
TRISHULI COLONY TO CHAMPANI
(GHATTA-UTTARGAYA)

DESIGNED BY :

DRAWN BY :

CHECKED BY :

APPROVED BY :

SCALE



CROSS SECTIONS

CH 0+000.00-0+050.00

DATE:

DRG NO : 2

SHEET NO : 1

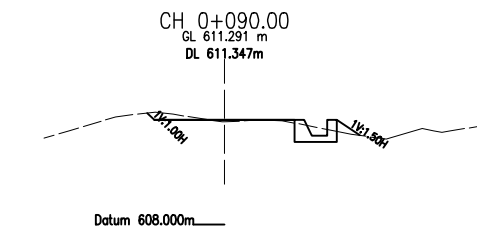
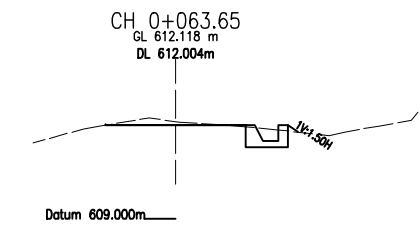
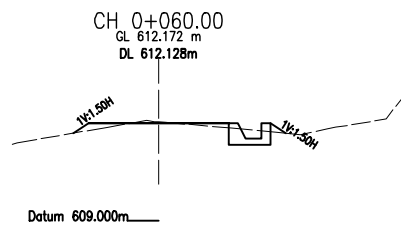
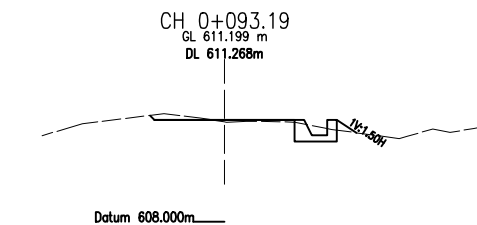
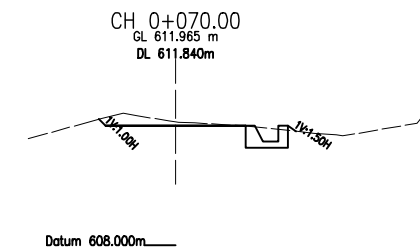
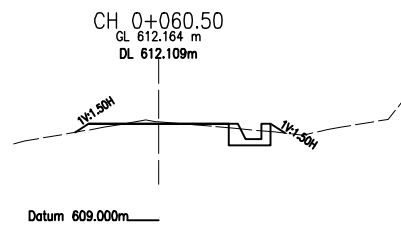
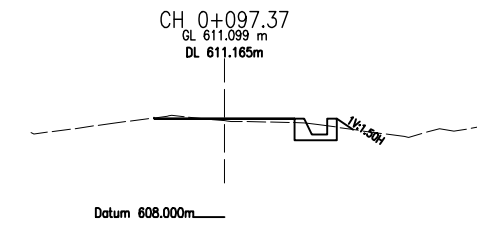
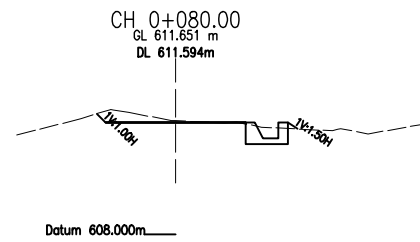
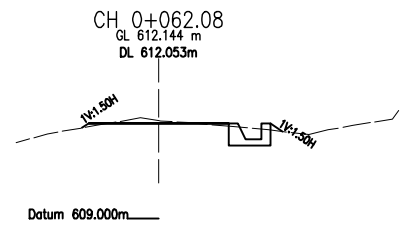

**NEPAL ELECTRICITY AUTHORITY
UPPER TRISHULI 3A HYDRO ELECTRIC PROJECT**

**UPGRADING EXISTING ROAD
TRISHULI COLONY TO CHAMPANI
(GHATTA-UTTARGAYA)**

DESIGNED BY :

DRAWN BY :

CHECKED BY :

APPROVED BY :

SCALE



CROSS SECTIONS

CH 0+060.00-0+097.37

DATE:

DRG NO : 2

SHEET NO : 2

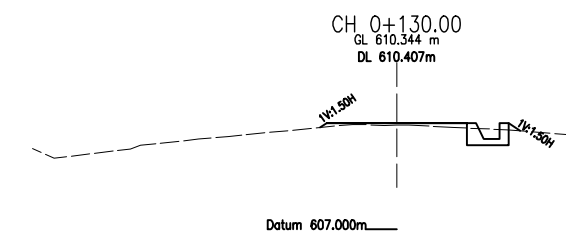
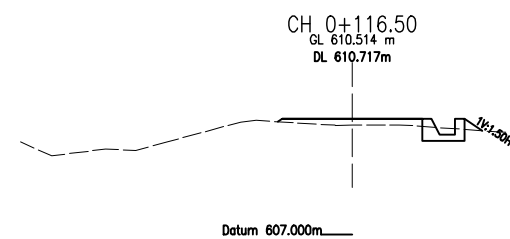
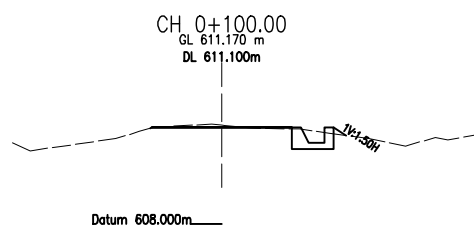
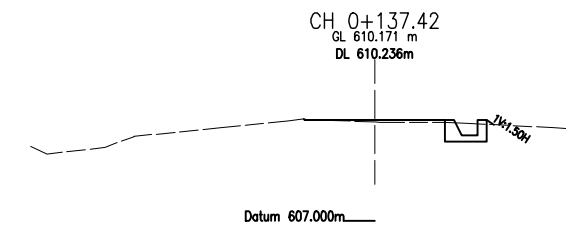
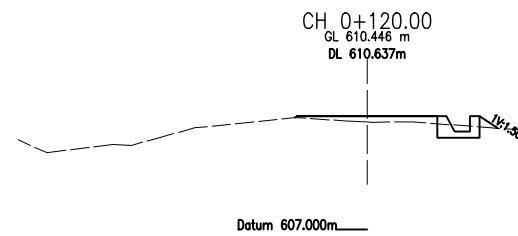
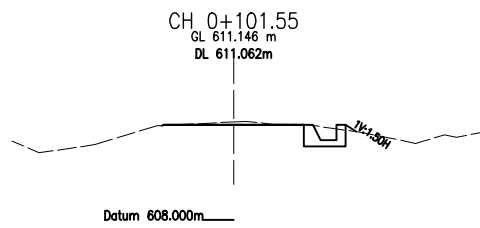
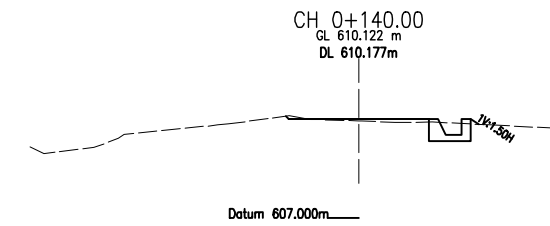
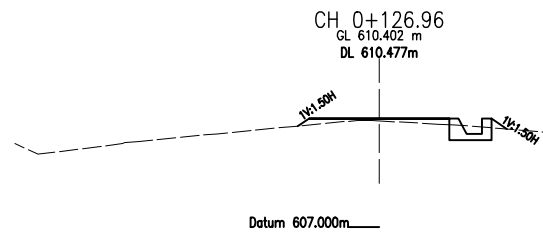
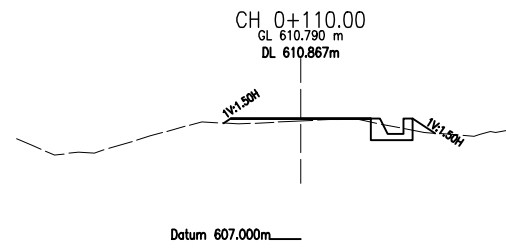

**NEPAL ELECTRICITY AUTHORITY
UPPER TRISHULI 3A HYDRO ELECTRIC PROJECT**

**UPGRADING EXISTING ROAD
TRISHULI COLONY TO CHAMPANI
(GHATTA-UTTARGAYA)**

DESIGNED BY :

DRAWN BY :

CHECKED BY :

APPROVED BY :

SCALE



CROSS SECTIONS

CH 0+100.00-0+140.00

DATE:

DRG NO : 2

SHEET NO : 3

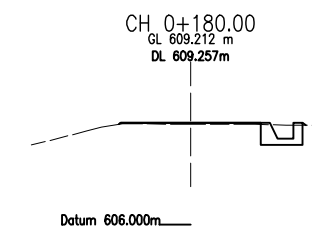
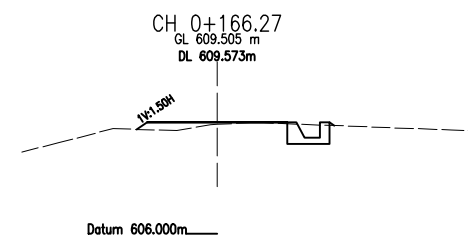
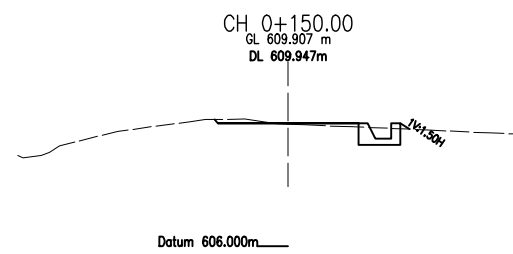
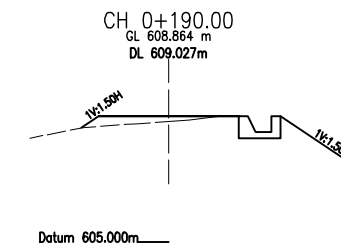
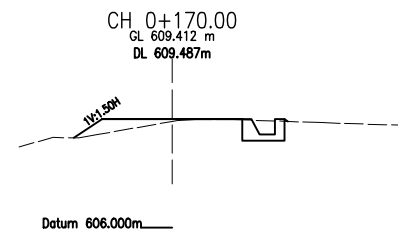
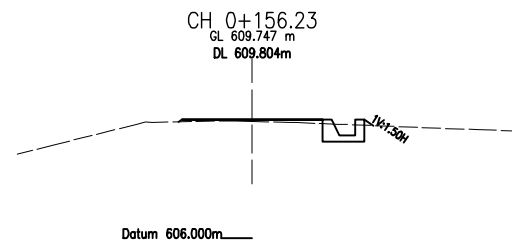
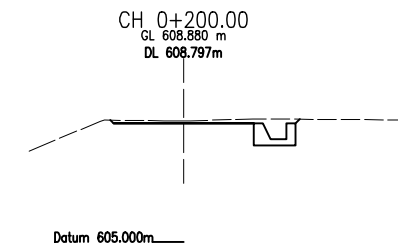
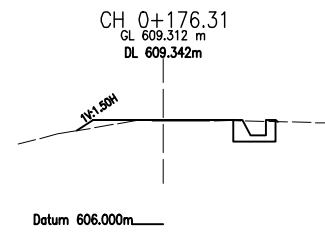
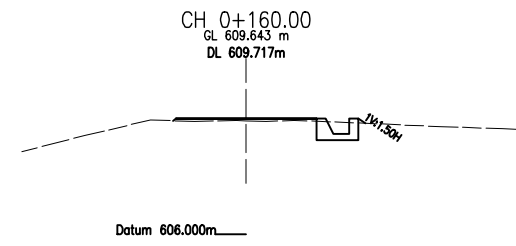

**NEPAL ELECTRICITY AUTHORITY
UPPER TRISHULI 3A HYDRO ELECTRIC PROJECT**

**UPGRADING EXISTING ROAD
TRISHULI COLONY TO CHAMPANI
(GHATTA-UTTARGAYA)**

DESIGNED BY :

DRAWN BY :

CHECKED BY :

APPROVED BY :

SCALE



CROSS SECTIONS

CH 0+150.00-0+200.00

DATE:

DRG NO : 2

SHEET NO : 4

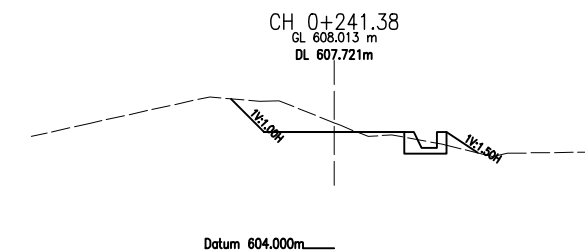
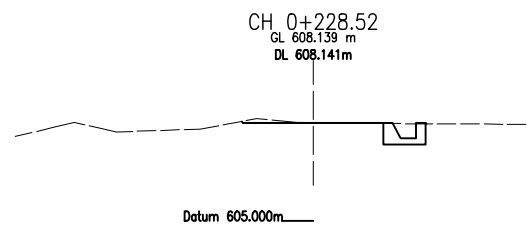
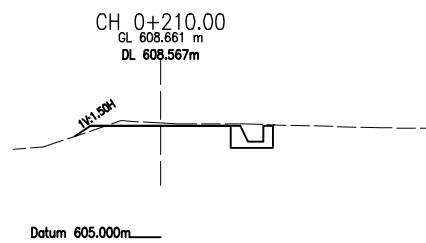
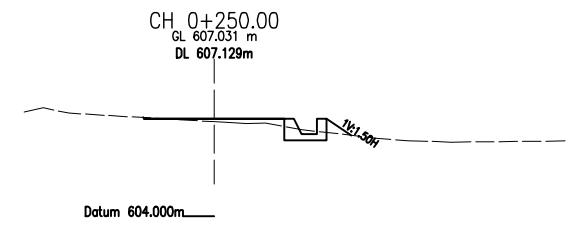
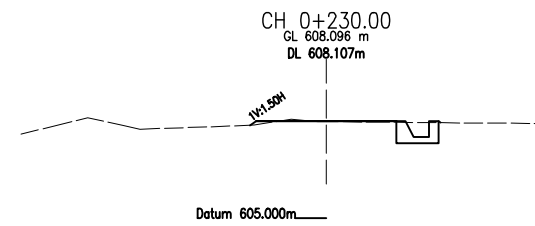
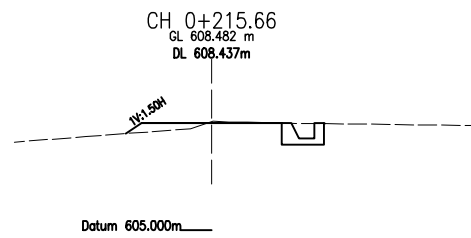
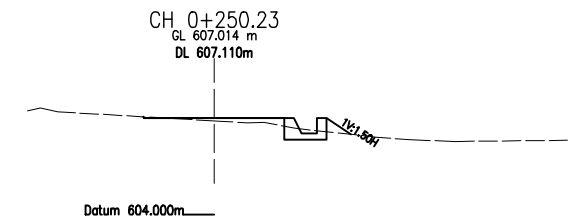
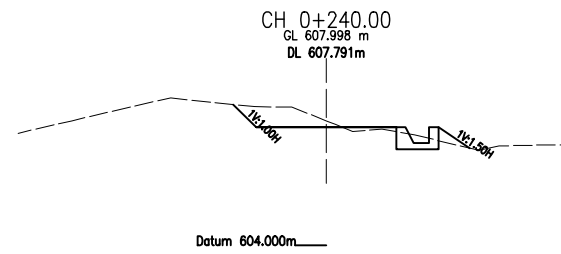
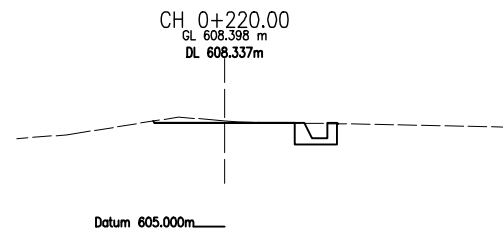

**NEPAL ELECTRICITY AUTHORITY
UPPER TRISHULI 3A HYDRO ELECTRIC PROJECT**

**UPGRADING EXISTING ROAD
TRISHULI COLONY TO CHAMPANI
(GHATTA-UTTARGAYA)**

DESIGNED BY :

DRAWN BY :

CHECKED BY :

APPROVED BY :

SCALE



CROSS SECTIONS

CH 0+210.00-0+250.23

DATE:

DRG NO : 2

SHEET NO : 5

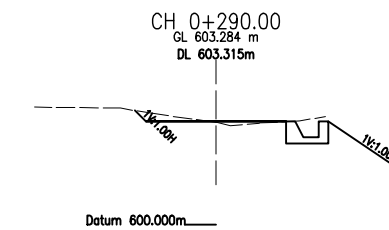
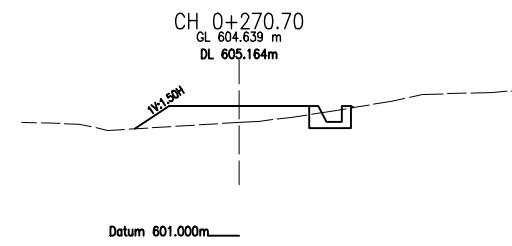
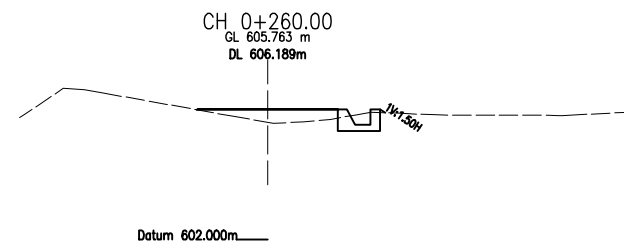
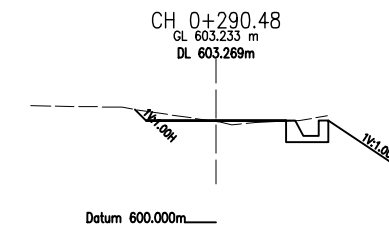
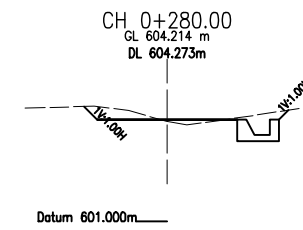
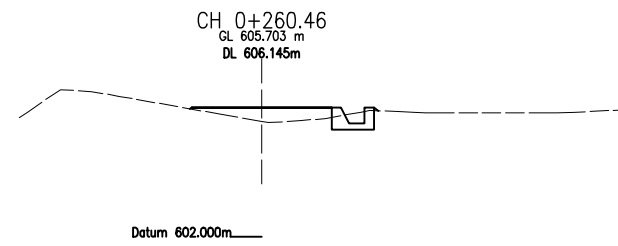
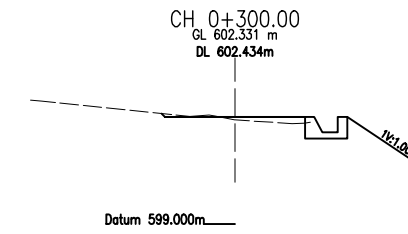
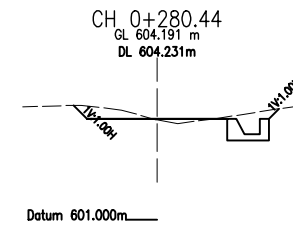
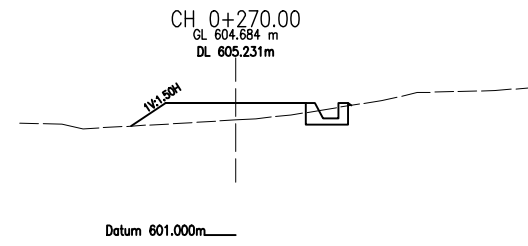

NEPAL ELECTRICITY AUTHORITY
UPPER TRISHULI 3A HYDRO ELECTRIC PROJECT

UPGRADING EXISTING ROAD
TRISHULI COLONY TO CHAMPANI
(GHATTA-UTTARGAYA)

DESIGNED BY :

DRAWN BY :

CHECKED BY :

APPROVED BY :



CROSS SECTIONS
CH 0+260.00-0+300.00

DATE:

DRG NO : 2

SHEET NO : 6

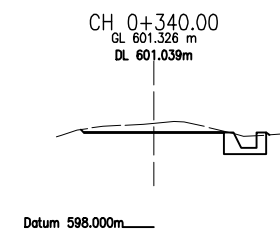
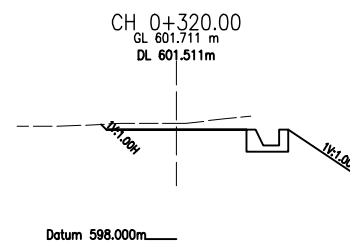
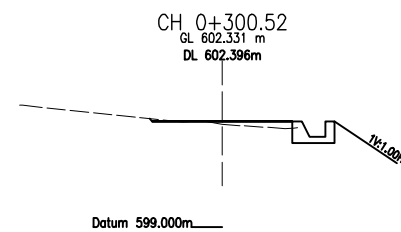
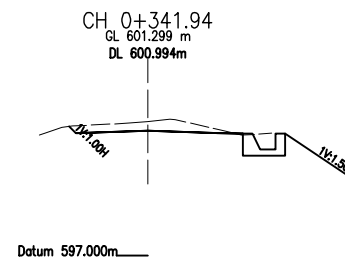
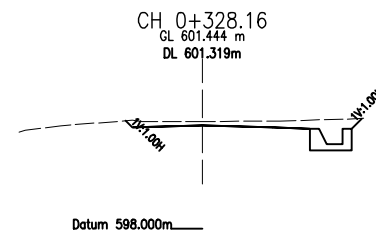
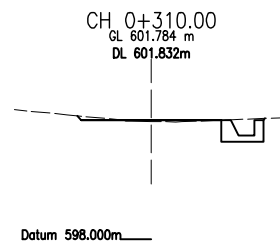
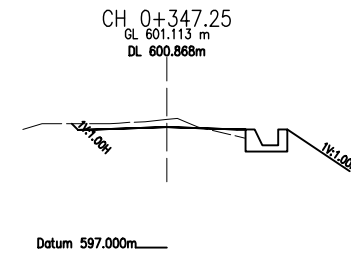
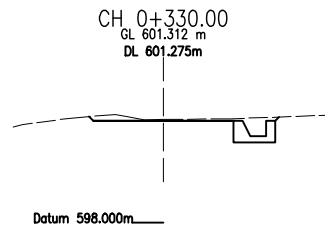
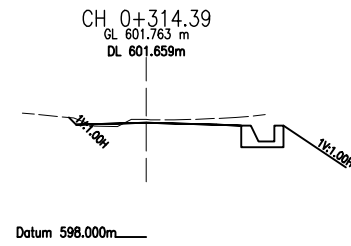

**NEPAL ELECTRICITY AUTHORITY
UPPER TRISHULI 3A HYDRO ELECTRIC PROJECT**

**UPGRADING EXISTING ROAD
TRISHULI COLONY TO CHAMPANI
(GHATTA-UTTARGAYA)**

DESIGNED BY :

DRAWN BY :

CHECKED BY :

APPROVED BY :

SCALE



CROSS SECTIONS

CH 0+300.52-0+347.25

DATE:

DRG NO : 2

SHEET NO : 7

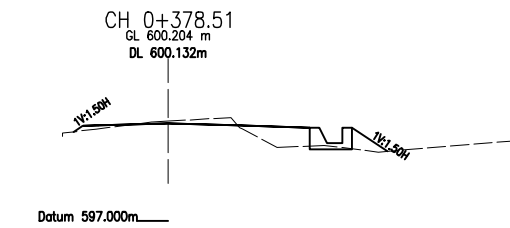
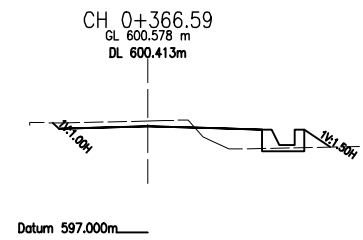
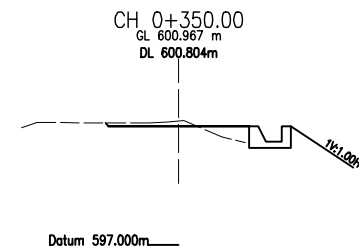
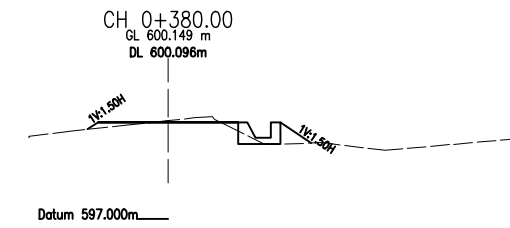
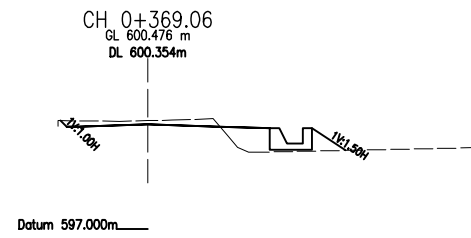
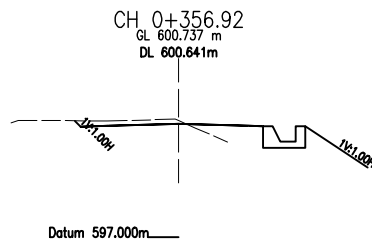
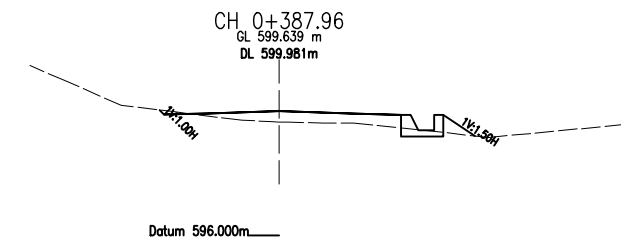
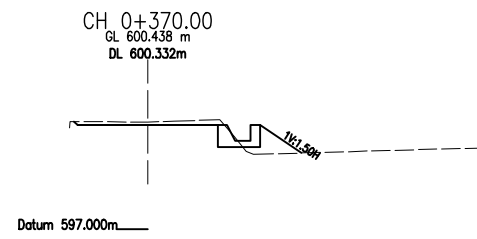
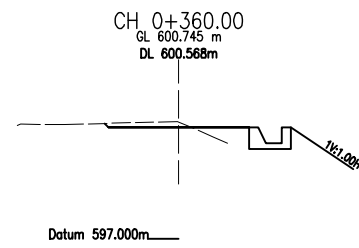

**NEPAL ELECTRICITY AUTHORITY
UPPER TRISHULI 3A HYDRO ELECTRIC PROJECT**

**UPGRADING EXISTING ROAD
TRISHULI COLONY TO CHAMPANI
(GHATTA-UTTARGAYA)**

DESIGNED BY :

DRAWN BY :

CHECKED BY :

APPROVED BY :

SCALE



CROSS SECTIONS

CH 0+350.00-0+387.96

DATE:

DRG NO : 2

SHEET NO : 8

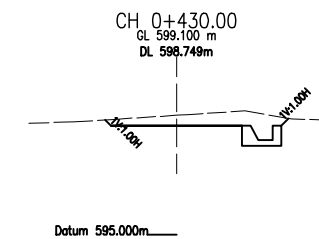
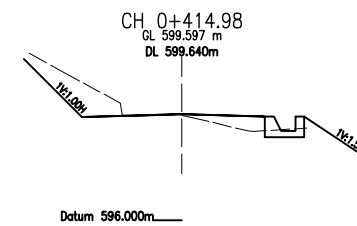
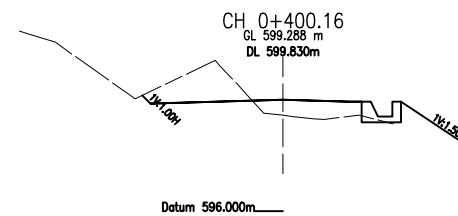
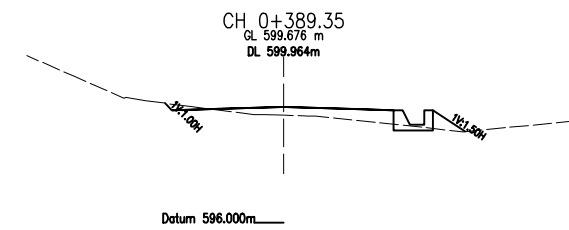
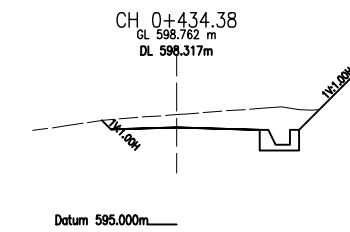
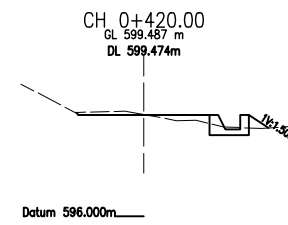
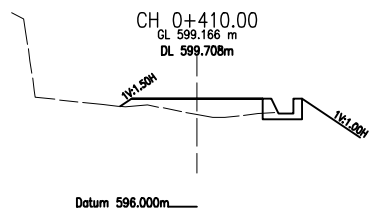
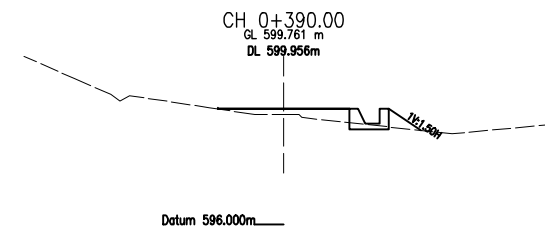
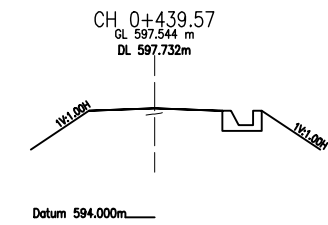
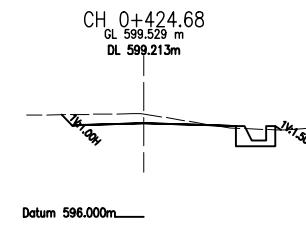
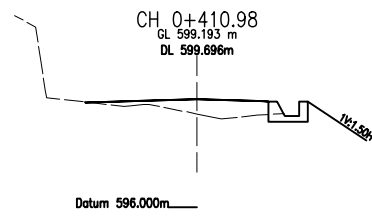
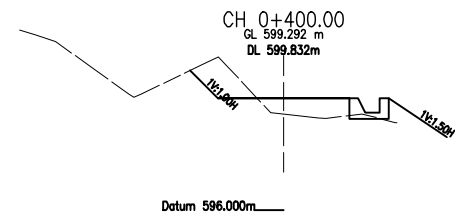

**NEPAL ELECTRICITY AUTHORITY
UPPER TRISHULI 3A HYDRO ELECTRIC PROJECT**

**UPGRADING EXISTING ROAD
TRISHULI COLONY TO CHAMPANI
(GHATTA-UTTARGAYA)**

DESIGNED BY :

DRAWN BY :

CHECKED BY :

APPROVED BY :

SCALE



CROSS SECTIONS

CH 0+389.35-0+0439.57

DATE:

DRG NO : 2

SHEET NO : 9



TYPICAL SECTIONS

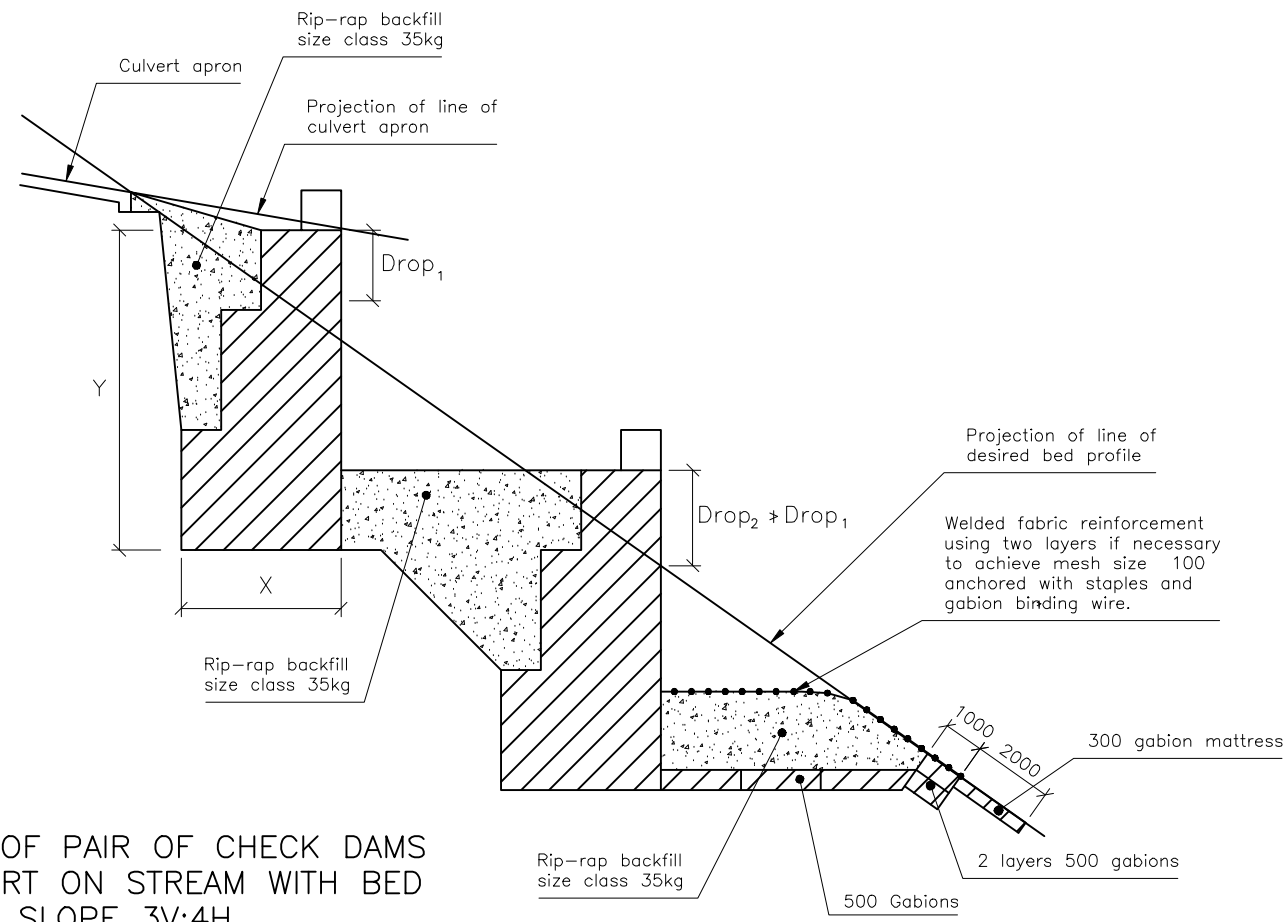

TYPICAL ARRANGEMENT OF PAIR OF CHECK DAMS DOWNSTREAM OF CULVERT ON STREAM WITH BED OF ERODIBLE MATERIAL. SLOPE 3V:4H

Notes:

1. Water dropping over check dam or the final check on a series of dams has a high scour and erosion potential which will cause the structure to fail if not controlled. The measures proposed are designed to form a plunge pool for controlled energy dissipation. The use of rip-rap is to provide a guaranteed grading of bed material in the pool sufficient to withstand the turbulence which will occur.
2. Dimensions X and Y determined by slope geometry and stability considerations.
3. The disturbance of beds and banks of streams shall be limited to the required for construction of the permanent works.
4. Rip-rap backfill size class 35kg shall be used for downstream protection. When the D_{95} of the bed material is less than the D_{95} of the rip-rap.
5. Welded fabric reinforcement for rip-rap apron shall have a minimum wire size of 6mm.
6. Concrete to crest class 250/20
7. Gabion mesh size 80 x 100 mm, Mattress mesh size 60 x 80mm
8. Foundation bearing surfaces shall be horizontal. Unsuitable material shall be replaced with suitable fill.

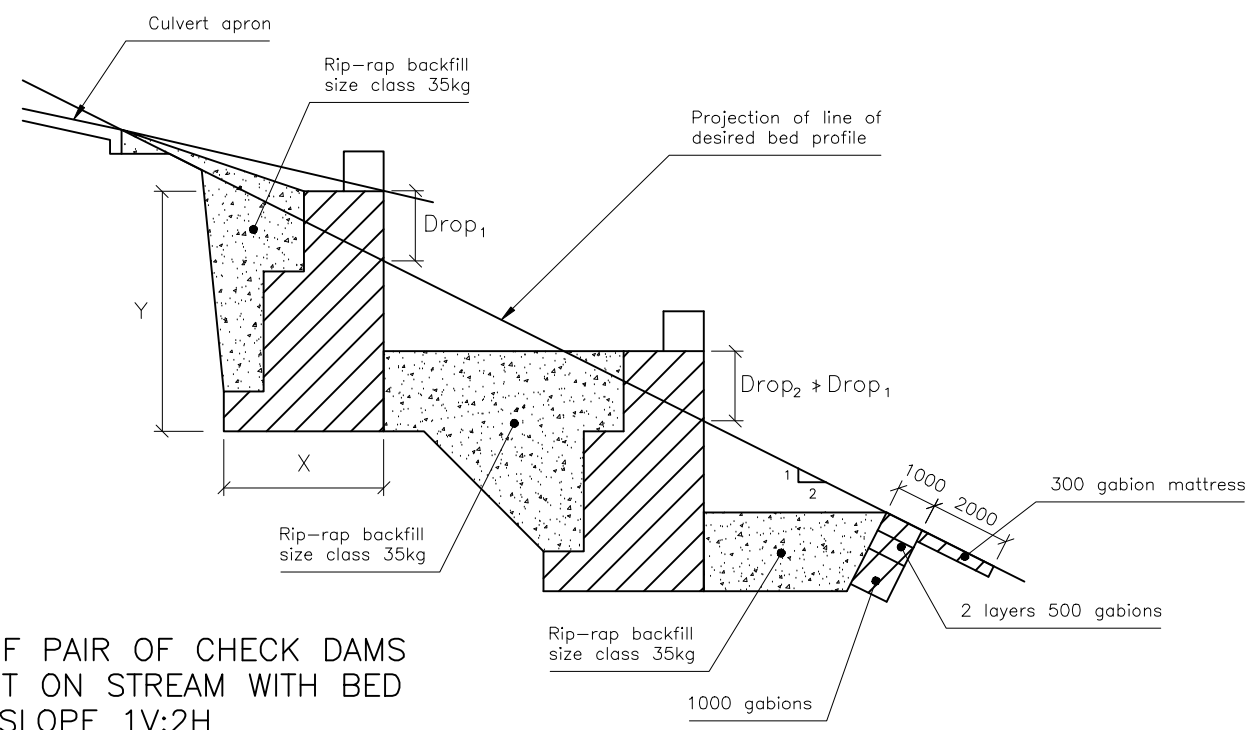

TYPICAL ARRANGEMENT OF PAIR OF CHECK DAMS DOWNSTREAM OF CULVERT ON STREAM WITH BED OF ERODIBLE MATERIAL. SLOPE 1V:2H

NEPAL ELECTRICITY AUTHORITY UPPER TRISHULI 3A HYDRO ELECTRIC PROJECT	UPGRADING EXISTING ROAD TRISHULI COLONY TO CHAMPANI	DESIGNED BY :	SCALE NOT IN SCALE	TYPICAL SECTIONS	DATE:
		DRAWN BY :			GABION CHECK DAMS DETAILS
		CHECKED BY :		SHEET NO : 1	
		APPROVED BY :			

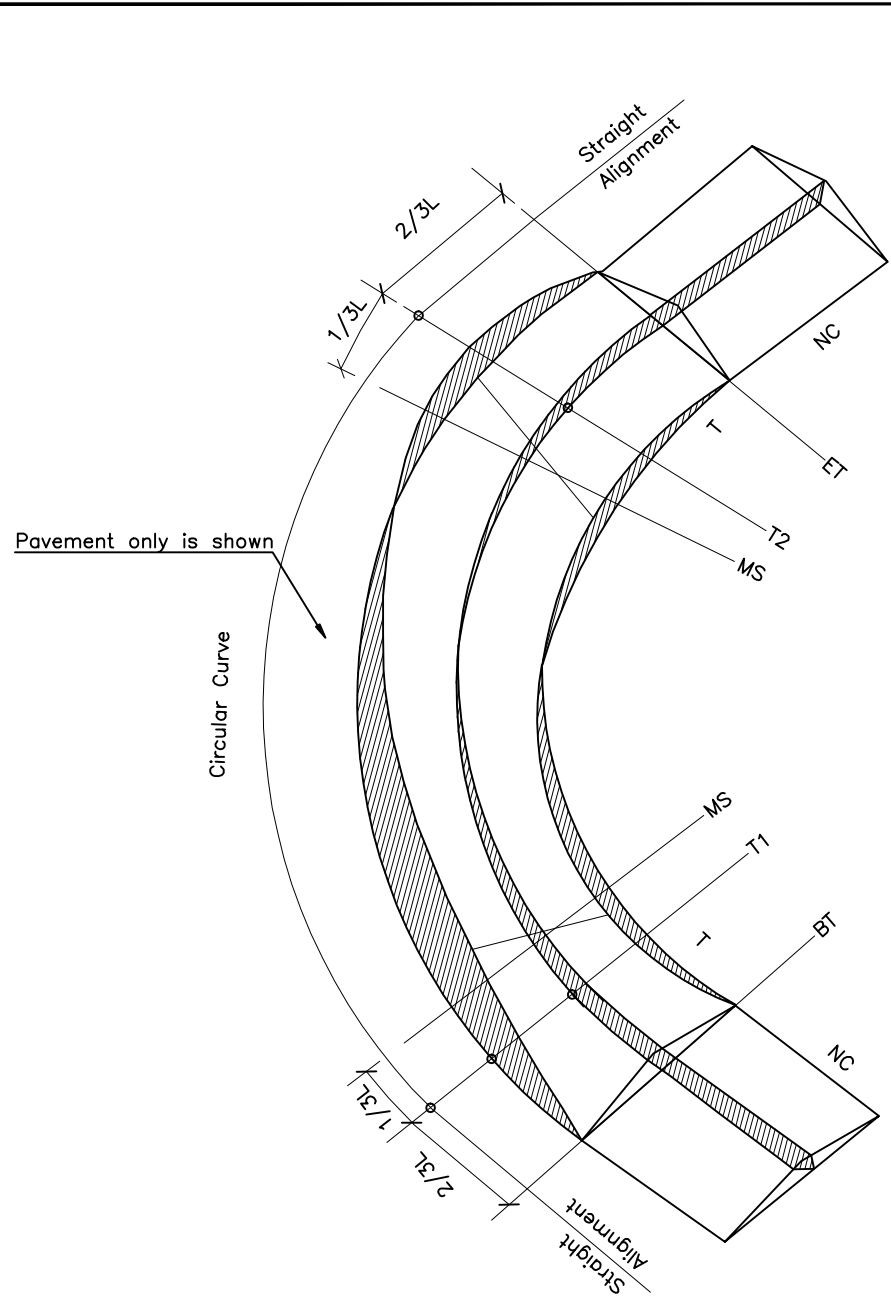

Typical Superelevation

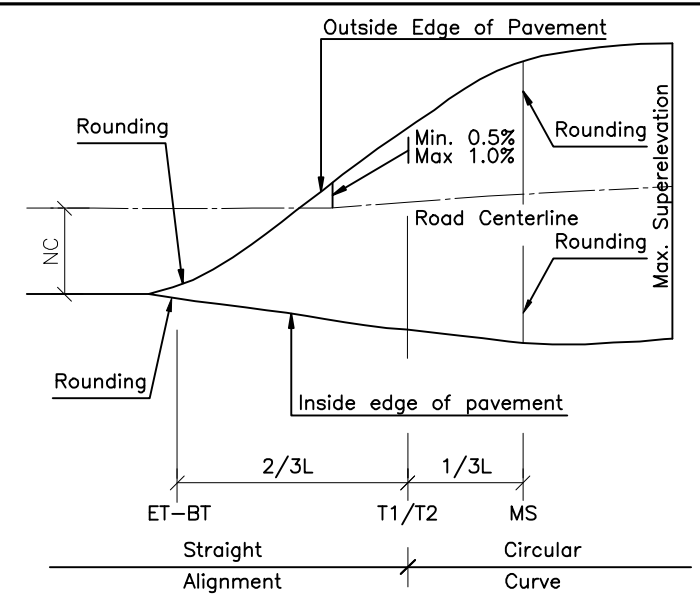

Cross Slope in Curves

Note:
For Circular horizontal curves the length L of superelevation run-off is based on maximum relative slope between profile of center line and pavement edge of 1.0%.

Transition Curve Detail
Transition Length
Mountainous and Steep Terrain

Curve Radius (Meters)	Design Speed in km/h				
	50	40	30	25	20
	Transition Length in Meters				
14				NA	30
20				35	20
25			NA	25	20
30			30	25	15
40		NA	25	20	15
50		40	20	15	15
55		40	20	15	15
70	NA	30	15	15	15
80	55	25	15	15	NR
90	45	25	15	15	
100	45	20	15	15	
125	35	15	15	NR	
150	30	15	15		
170	25	15	NR		
200	20	15			
250	15	15			
300	15	NR			
400	15				
500	NR				

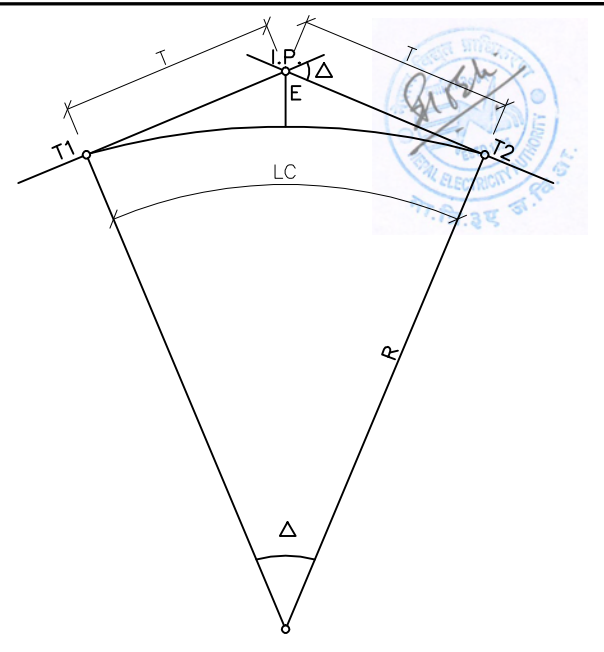

Circular Curve
For Horizontal Alignment

- I.P. = Intersection Point
- Δ = Deflection Angle
- R = Radius of Curvature
- T = Tangent length
- E = Distance from I.P. to Circular Curve Measured on the Bisectors
- LC = Length of Circular Curve
- T1 = Beginning of Circular Curve
- T2 = End of Circular Curve
- $T = R \cdot \tan \frac{\Delta}{2}$
- $E = R \cdot \left(\frac{1}{\cos \frac{\Delta}{2}} - 1 \right)$
- $LC = R \cdot \frac{\pi}{200} \cdot \Delta$

- T.P., P.T = Tangent Point.
- H.I.P = Horizontal Intersection Point.
- Δ = Total Deviation Angle.
- Δc = Deviation and Central Angle of Circular arc.
- TS = Deviation Angle of Transition Curve.
- RC = Radius of Circular Curve.
- S = Shift.
- θs = Tangent Distance.
- ES = Apex Distance.
- LS = Length of Transition.
- LC = Length of Circular Curve.

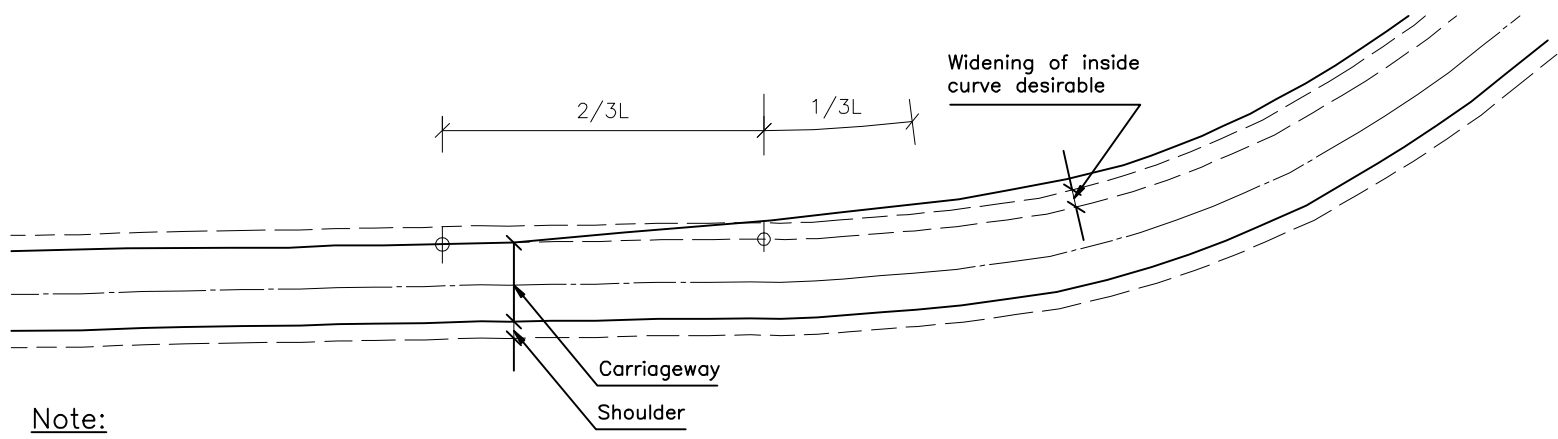

Note:
Widening to be attained over the length of superelevation run-off.

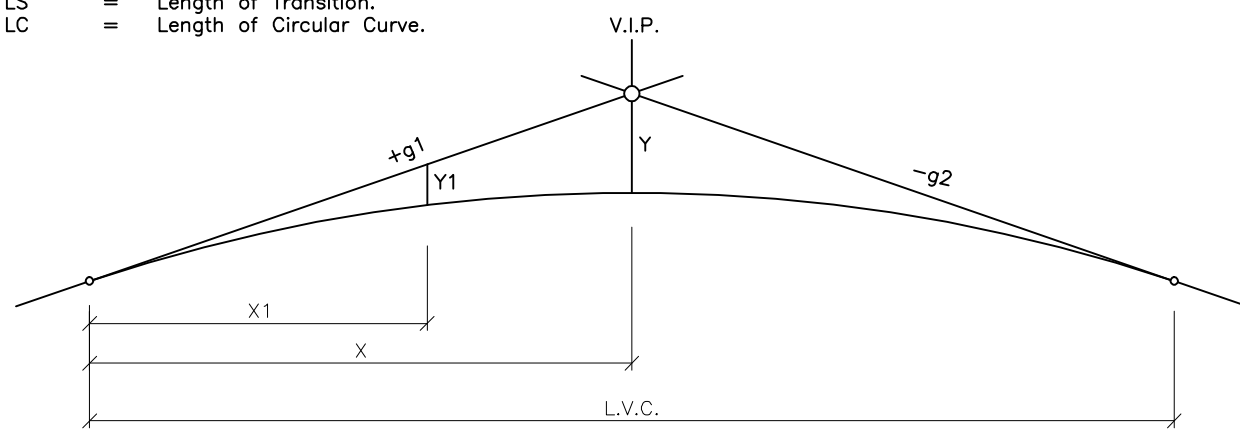

Parabolic Curve
For Vertical Alignment

- V.I.P. = Vertical Intersection Point.
- L.V.C = Length of Vertical Curve.
- ±g1, ±g2 = Gradients.
- Y, Y1 = Abscissa of the Vertical Curve.
- X, X1 = Ordinate of the Vertical Curve.
- $Y = X^2 \frac{\pm g_1 - (\pm g_2)}{2LVC}$

NEPAL ELECTRICITY AUTHORITY UPPER TRISHULI 3A HYDRO ELECTRIC PROJECT	UPGRADING EXISTING ROAD TRISHULI COLONY TO CHAMPANI	DESIGNED BY :	SCALE NOT IN SCALE	TYPICAL SECTIONS ELEMENTS OF HORIZONTAL AND VERTICAL CURVES	DATE:
		DRAWN BY :			DRG NO : 3
		CHECKED BY :		SHEET NO : 2	
		APPROVED BY :			



5TH KILOMETRE POST

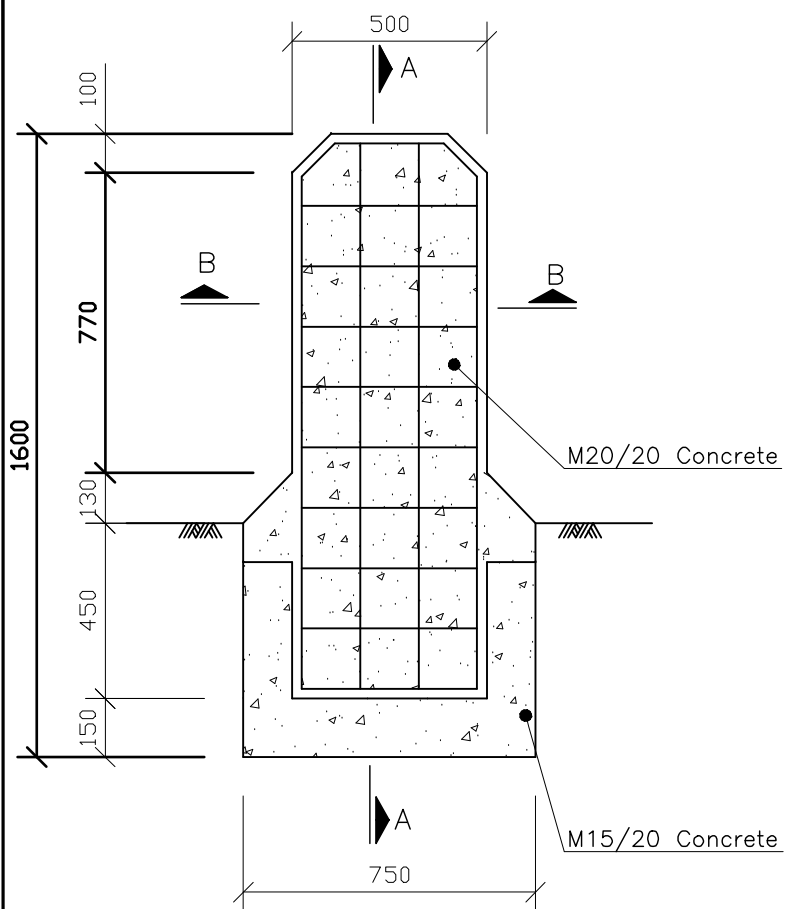

SECTIONAL ELEVATION

KILOMETRE POST

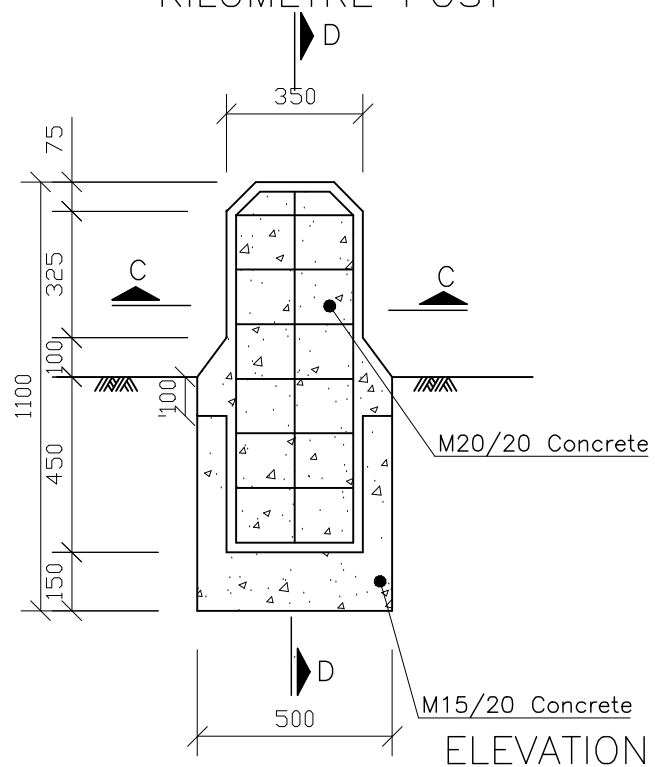

ELEVATION

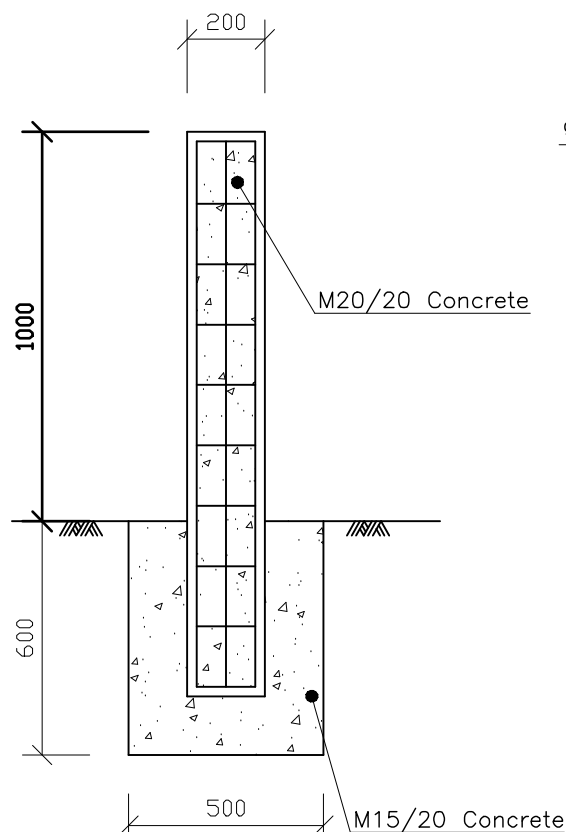

SECTION A-A

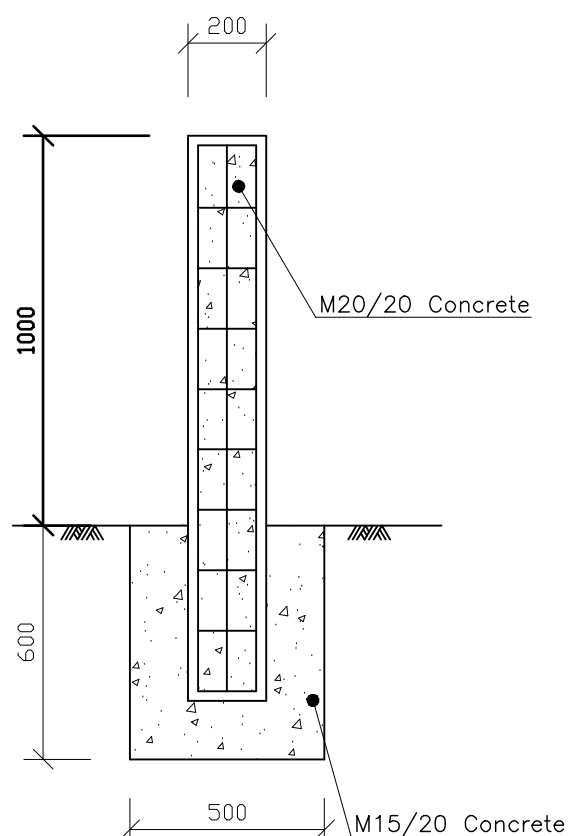

SECTION D-D

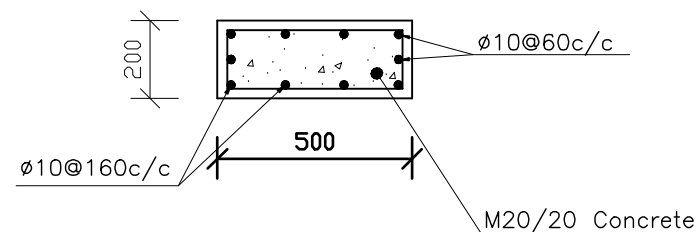

SECTION B-B

LOCATION OF K.M STONES

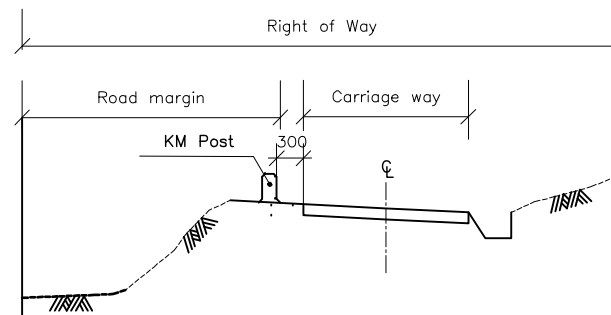

SECTIONAL ELEVATION

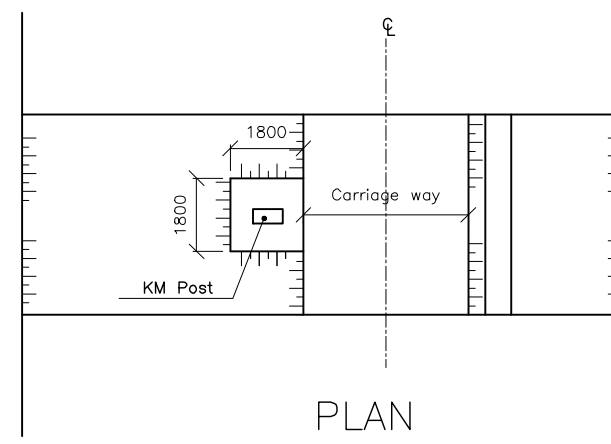

PLAN

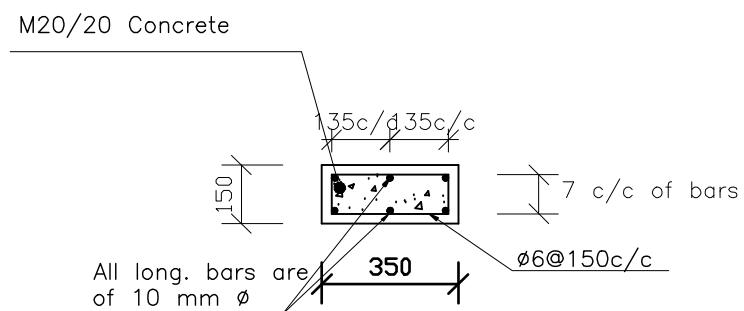

SECTION C-C

NEPAL ELECTRICITY AUTHORITY
UPPER TRISHULI 3A HYDRO ELECTRIC PROJECT

UPGRADING EXISTING ROAD
TRISHULI COLONY TO CHAMPANI

DESIGNED BY :

DRAWN BY :

CHECKED BY :

APPROVED BY :

SCALE

NOT IN SCALE

TYPICAL SECTIONS

ELEMENTS OF HORIZONTAL AND VERTICAL CURVES

DATE:

DRG NO : 3

SHEET NO : 3

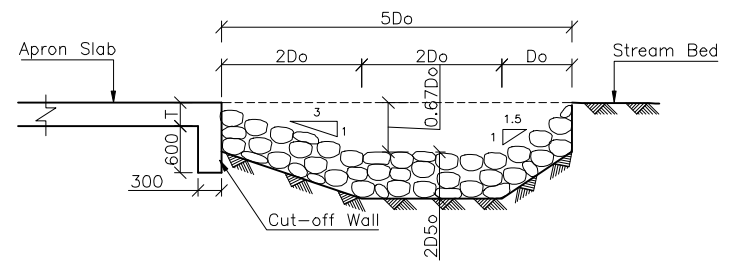

SECTION AT A-A

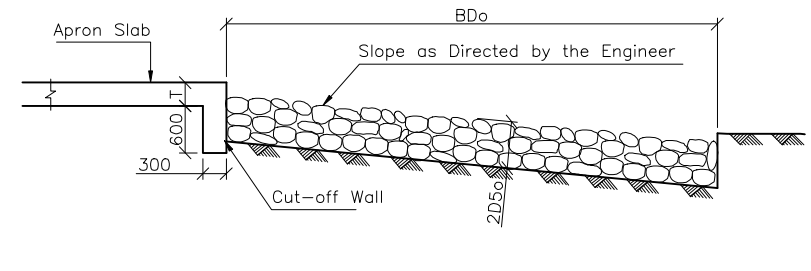

SECTION AT B-B

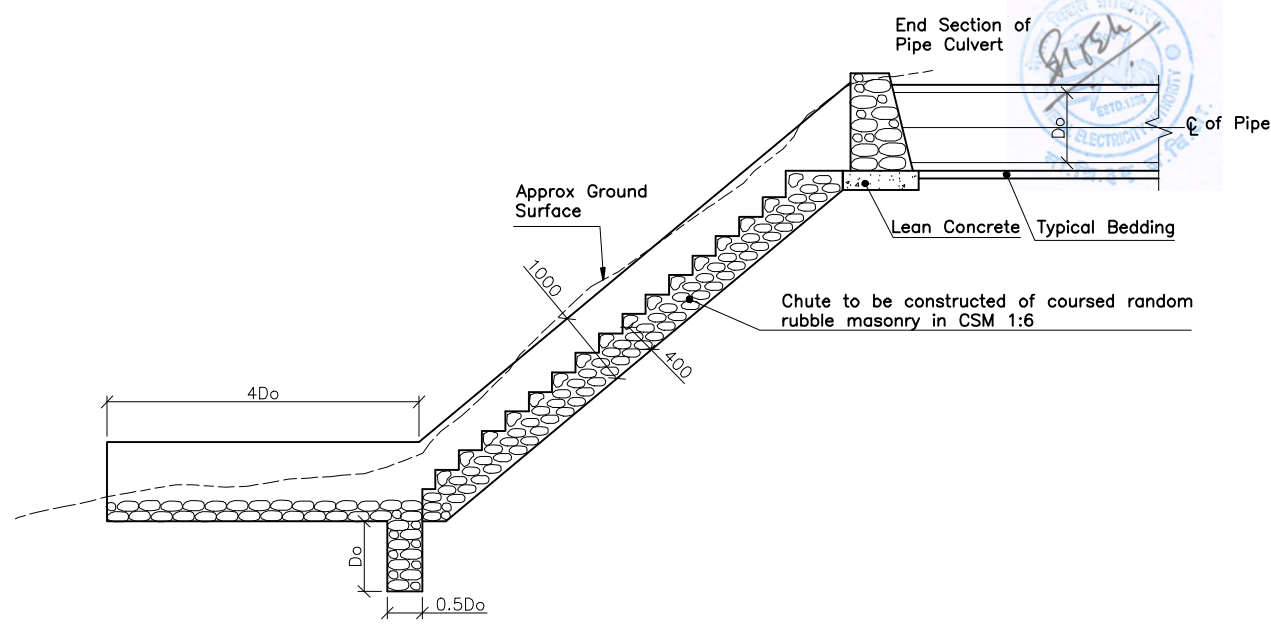

SECTION AT C-C

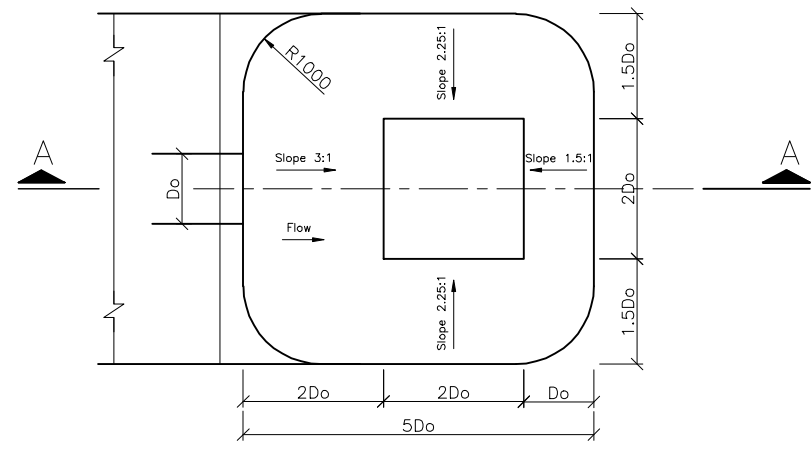

PLAN
RIPRAP OUTLET APRON
(PERFORMED SCOUR HOLE TYPE)

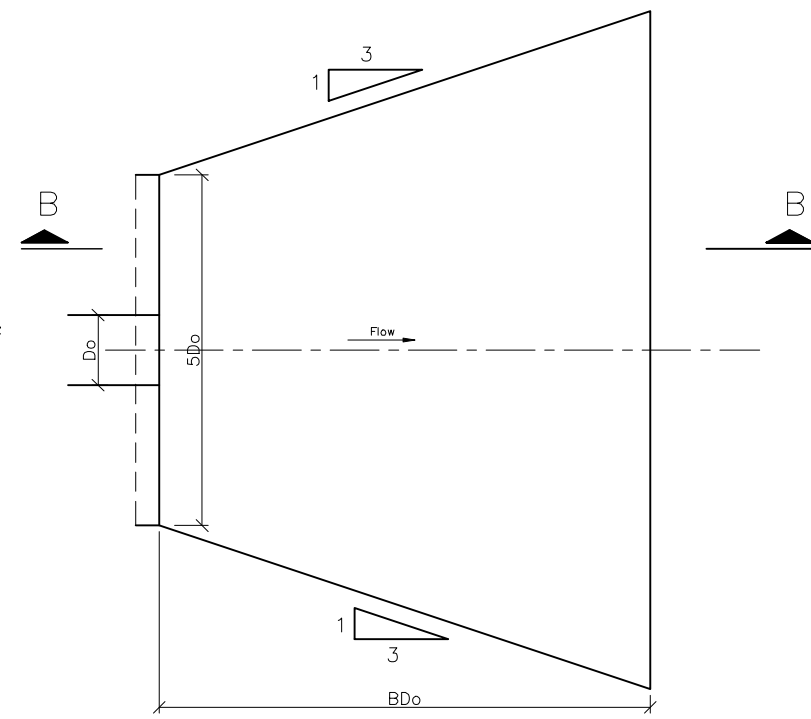

PLAN
RIPRAP OUTLET APRON
(HORIZONTAL TYPE)

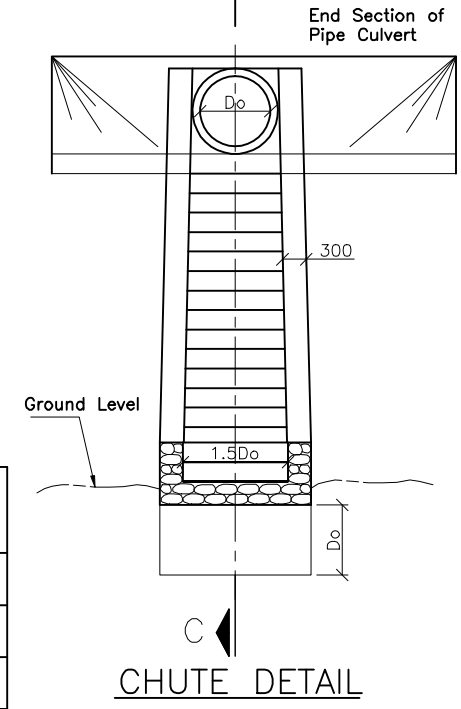

CHUTE DETAIL

- Notes:**
- Riprap outlet aprons shall be provided as specified.
 - Either a performed scour hole type apron or a horizontal type apron can be provided at sites, requiring a riprap outlet apron depending on ease of construction and as directed by the Engineer.
 - Riprap inlet aprons shall be provided as specified.
 - Riprap outlet apron or chute shall be provided for R.C pipe culverts where specified.
 - All Dimensions are in millimeters unless otherwise specified.

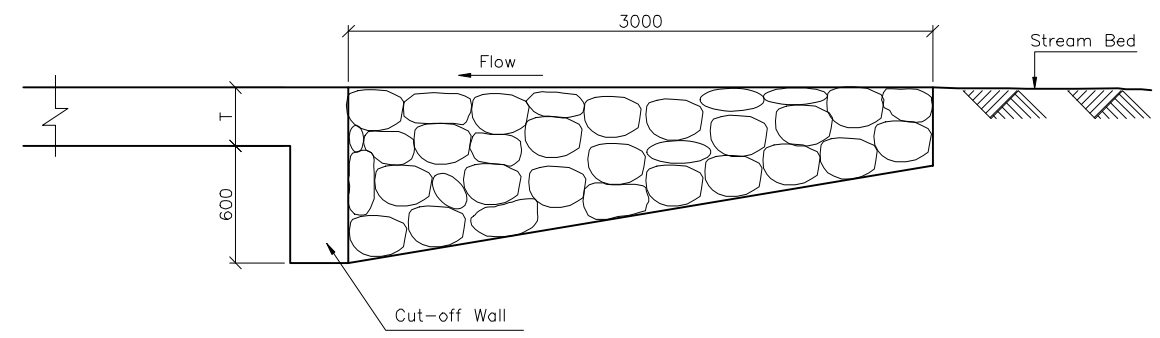

RIPRAP INLET APRON DETAIL

Do (M)	D5o (M) FOR P. SH. TYPE	D5o (M) FOR HORIZONTAL TYPE
600ø	100	150
900ø	120	200
1200ø	150	300
1.0 B	200	400
1.5 B	300	400
2.0 B	400	450
2.5 B	450	500
3.0 B	500	750

B = CLEAR CULVERT SPAN
D5o= RIPRAP SIZE
Do = PIPE INNER DIAMETER

NEPAL ELECTRICITY AUTHORITY
UPPER TRISHULI 3A HYDRO ELECTRIC PROJECT

UPGRADING EXISTING ROAD
TRISHULI COLONY TO CHAMPANI

DESIGNED BY :
DRAWN BY :
CHECKED BY :
APPROVED BY :

SCALE
NOT IN SCALE

TYPICAL SECTIONS
RIP RAP APRONS/CHUTE DETAILS

DATE:
DRG NO : 3
SHEET NO : 4

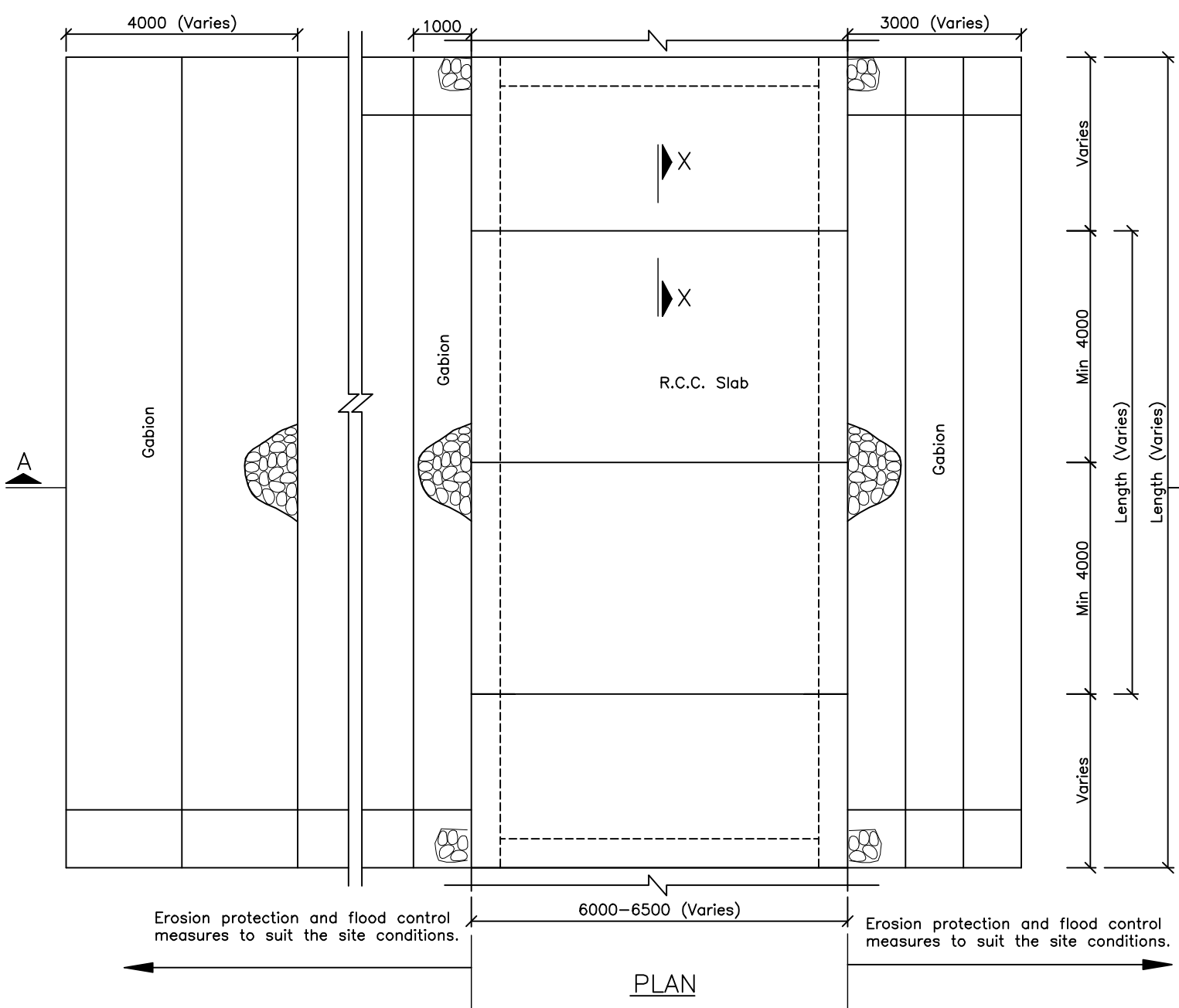

PLAN

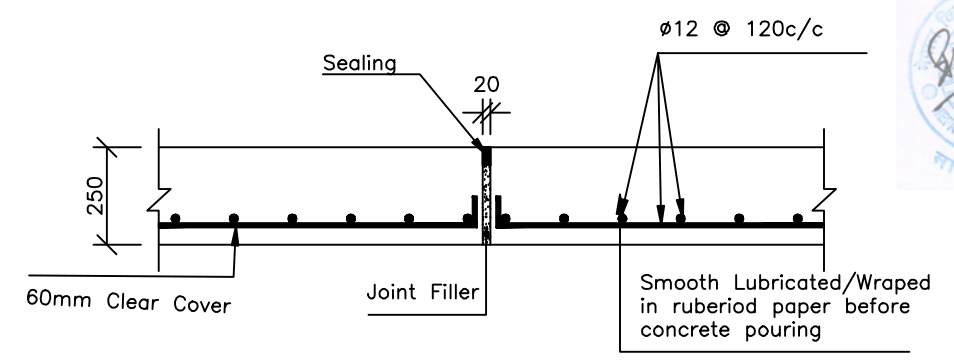

SECTION AT X-X
(EXPANSION JOINT AND REINFORCEMENT DETAILS IN SLAB)

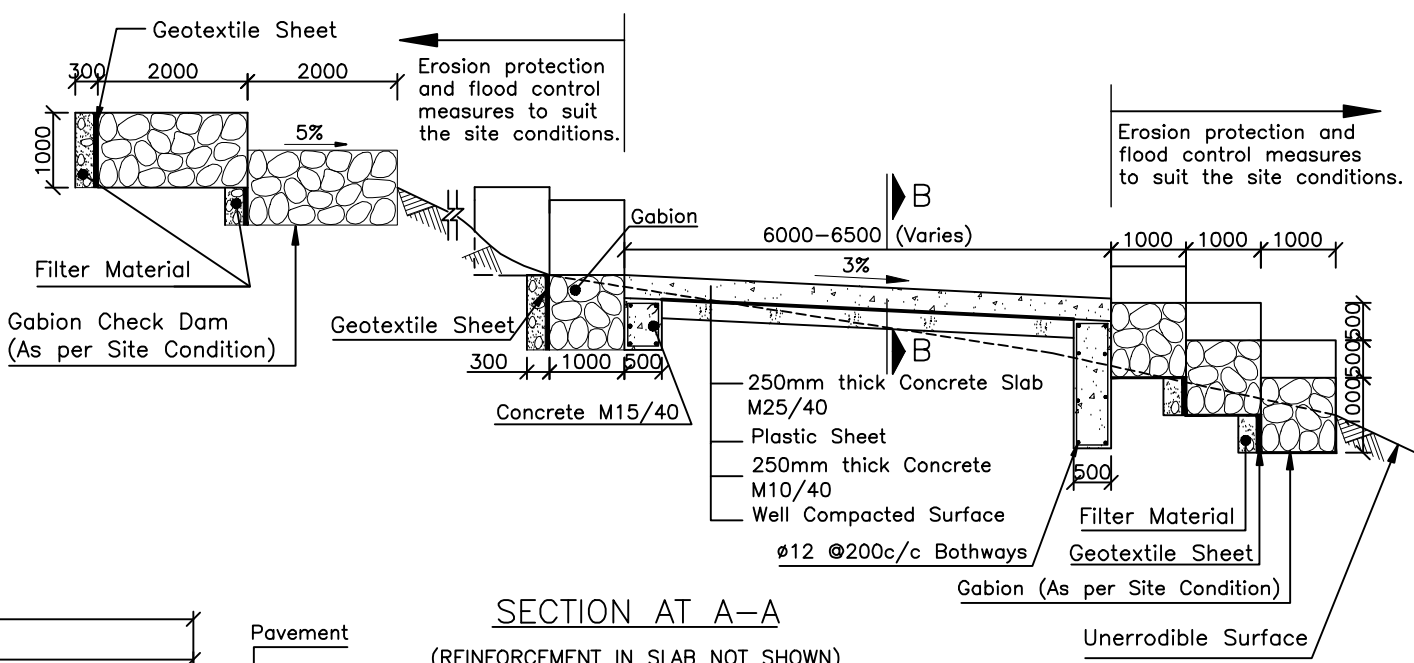

SECTION AT A-A
(REINFORCEMENT IN SLAB NOT SHOWN)

- NOTES :
1. All dimensions are in mm unless otherwise stated.
 2. Layout of the Causeways shall be as directed by the engineer as per site condition.
 3. Length and height of wall and other structure shall be as directed by the Engineer to suit the side conditions.
 4. In weak soil bottom reinforcement as per top layer shall be placed as directed by the Engineer.

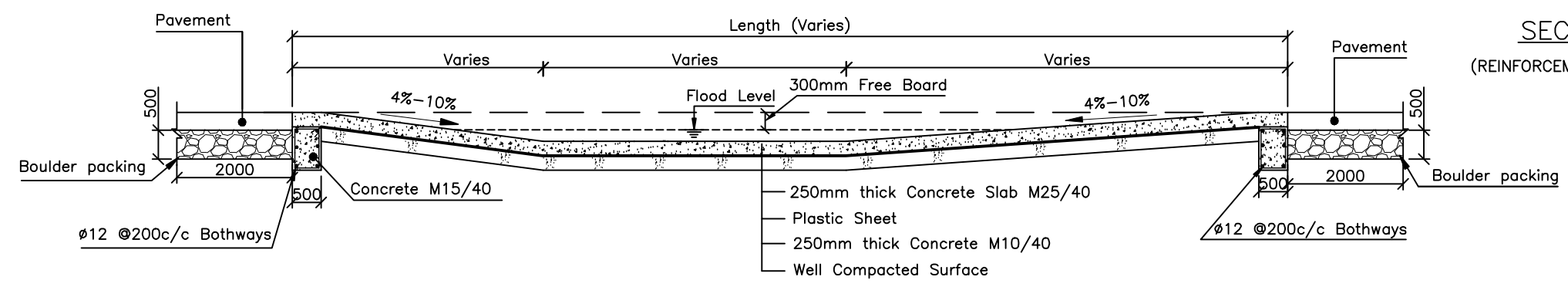

SECTION AT B-B
(REINFORCEMENT IN SLAB NOT SHOWN)

NEPAL ELECTRICITY AUTHORITY
UPPER TRISHULI 3A HYDRO ELECTRIC PROJECT

UPGRADING EXISTING ROAD
TRISHULI COLONY TO CHAMPANI

DESIGNED BY :
DRAWN BY :
CHECKED BY :
APPROVED BY :

SCALE
NOT IN SCALE

TYPICAL SECTIONS
TYPICAL CAUSEWAY DETAILS (TYPE A)

DATE:
DRG NO : 3
SHEET NO : 5

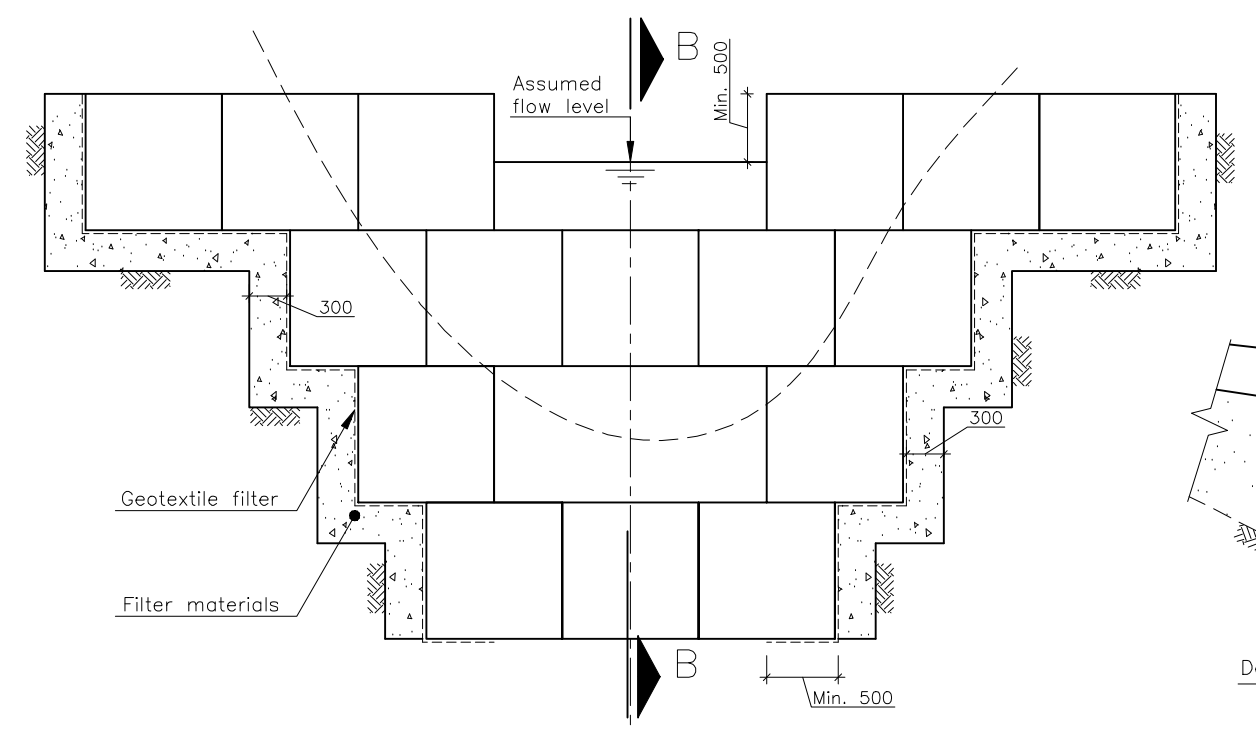

SECTION AT A-A

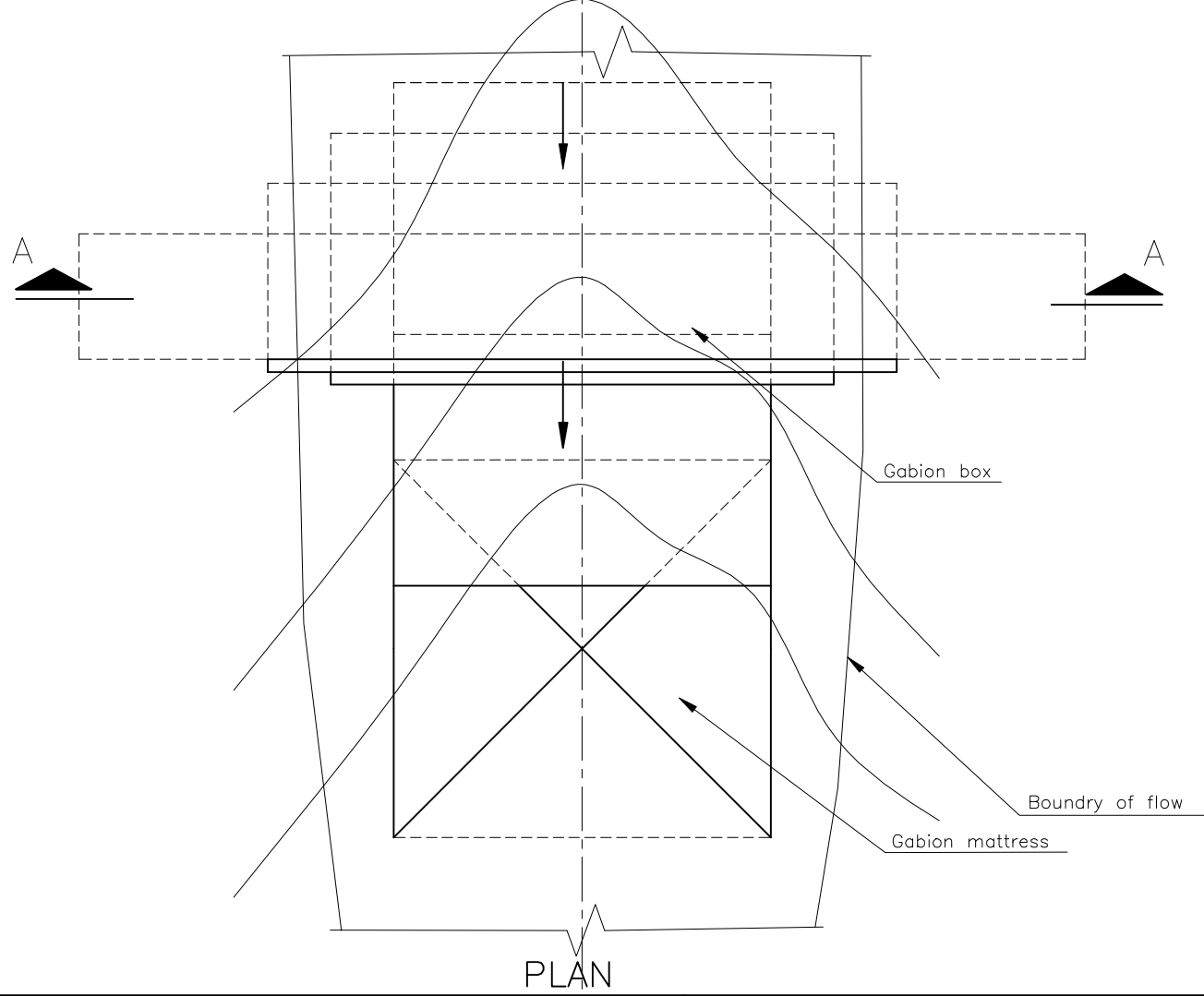

PLAN

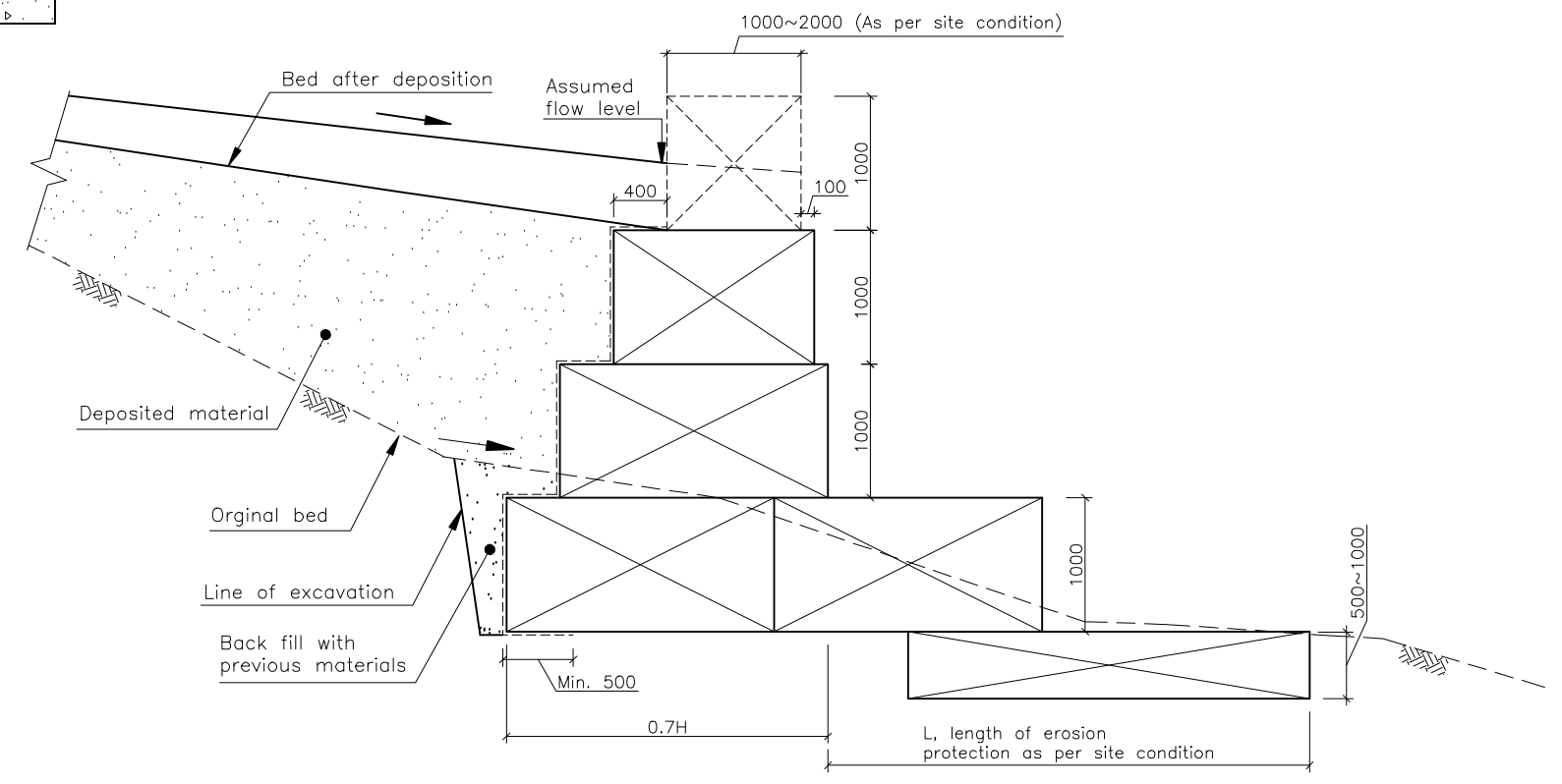

SECTION AT B-B

- Notes :
1. All dimensions are in mm unless otherwise stated.
 2. The sizes of the structure will be fixed as per site condition.
 3. The exact location of the check dam shall be as instructed by the Engineer as per site condition.

NEPAL ELECTRICITY AUTHORITY UPPER TRISHULI 3A HYDRO ELECTRIC PROJECT	UPGRADING EXISTING ROAD TRISHULI COLONY TO CHAMPANI	DESIGNED BY :	SCALE NOT IN SCALE	TYPICAL SECTIONS TYPICAL CHECK DAM DETAILS	DATE:
		DRAWN BY :			DRG NO : 3
		CHECKED BY :		SHEET NO : 6	
		APPROVED BY :			

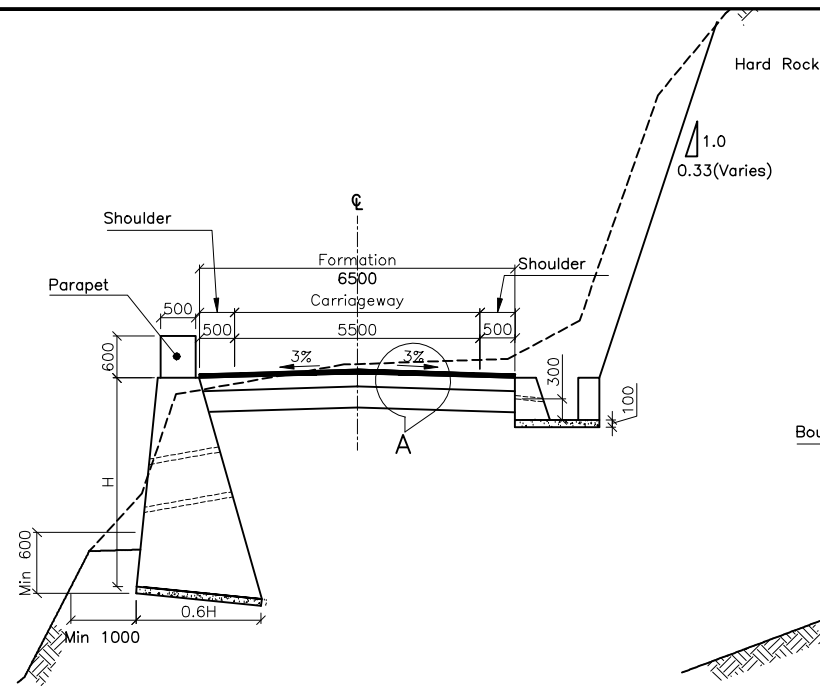

Typical Cross-section with Trapezoidal Wall

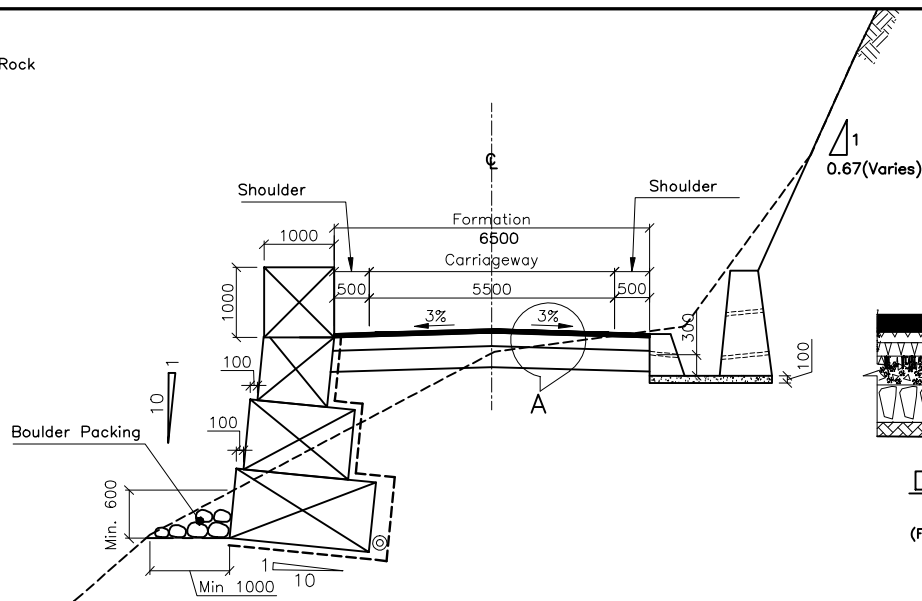

Typical Cross-section with D Type Drain

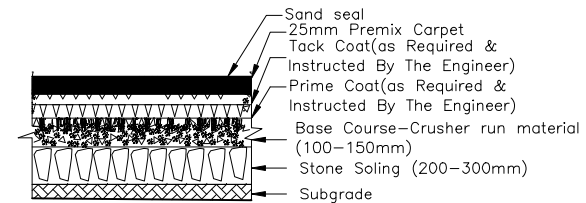

Detail At A (At high gradient area)

Not To Scale
(For details see Table)

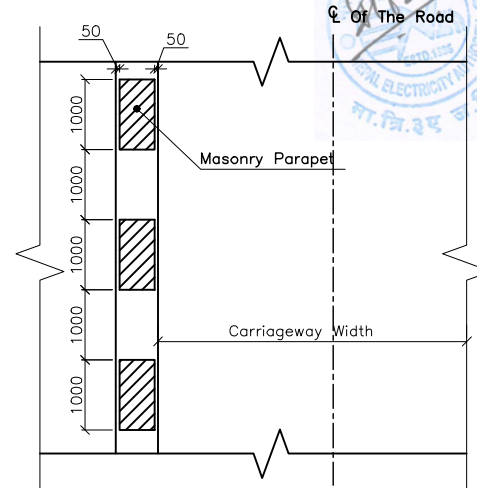

Plan
(Stone Masonry Parapet)

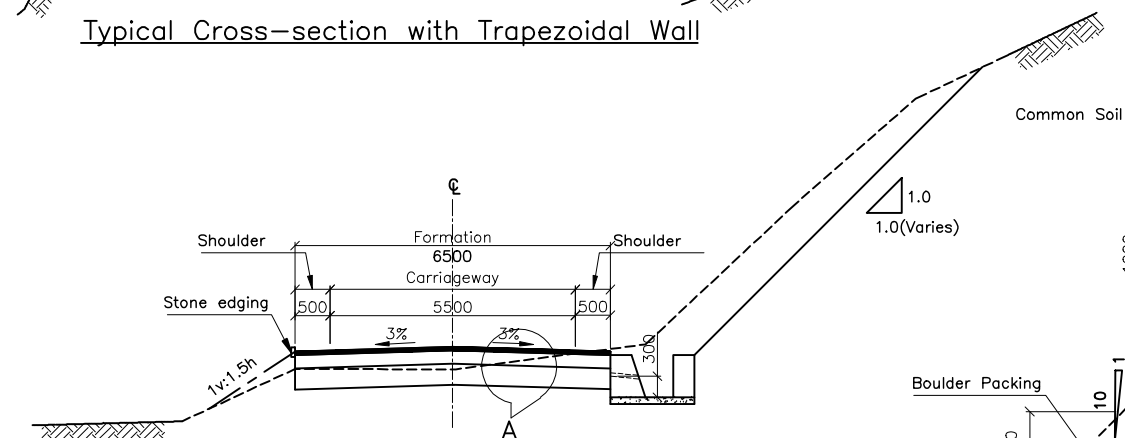

Typical Cross-section Without Wall

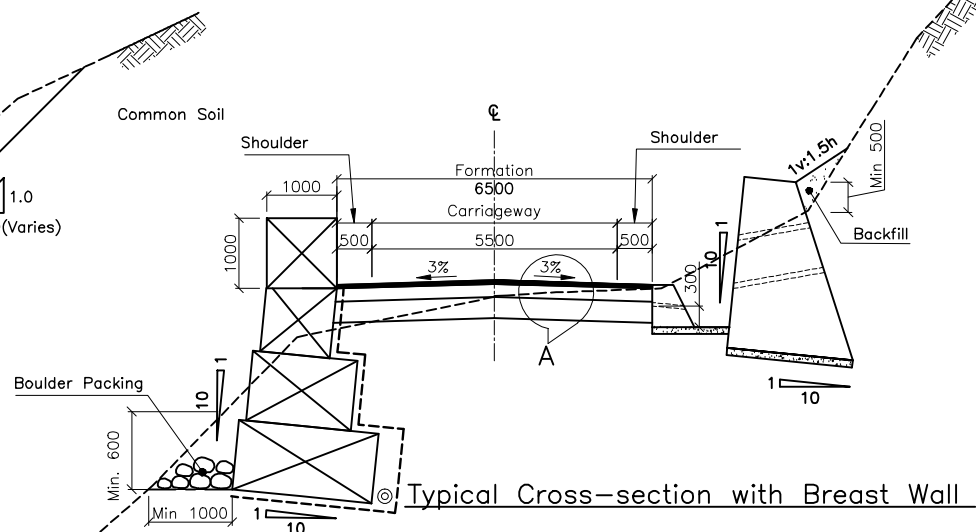

Typical Cross-section with Breast Wall

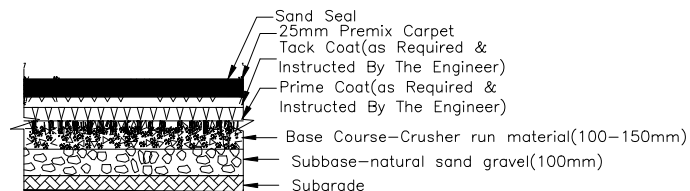

Detail At A

Not To Scale
(For details see Table)

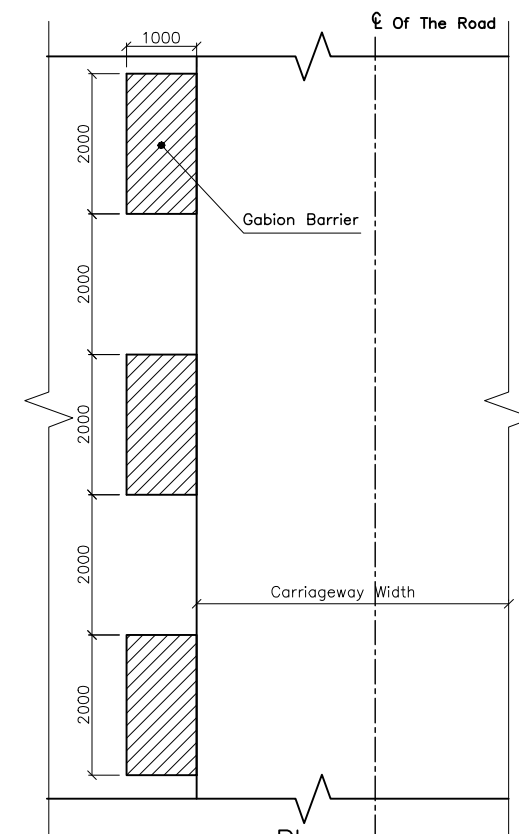

Plan
Gabion Barrier

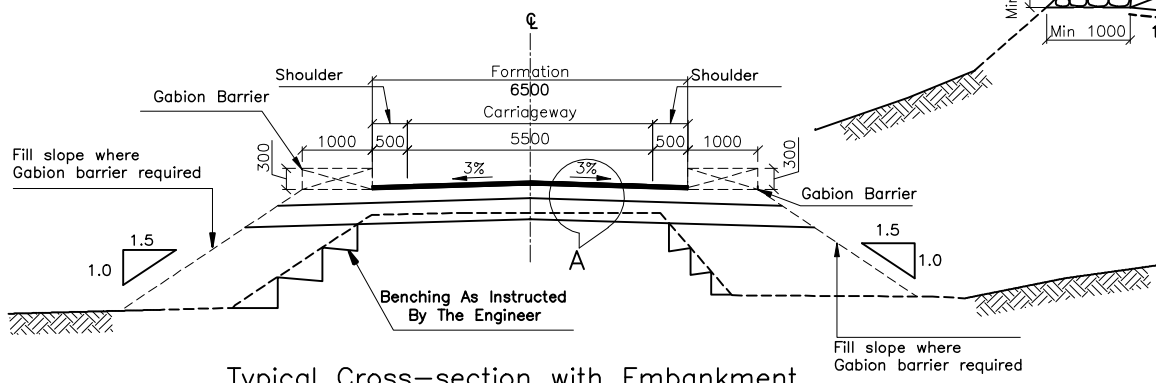

Typical Cross-section with Embankment

Notes :

- All dimensions are in millimeters.
- Unless otherwise shown in the drawings or as directed by the engineer, fill slopes shall be 1V:1.5H. In non-erodible soils fill slopes may be reduced to 1V:1.25H as directed by the engineer.
- Cut slopes shall be approximately 1V:1H to 1V:0.67H in common soil and approximately 1V:0.33H to 1V:0.25H in hard rock unless otherwise shown on the drawings or as directed by the engineer. In hard rock, slopes shall be cut at the same slope as the joints sloping to the roadway and may be as steep as 75°, in hard rock, where the height of cut exceeds 10 m, a bench shall be constructed at mid-height or, as directed by the engineer.
- Retaining walls are to be constructed where shown on the drawings or as directed by the engineer. In areas where upon excavation, soils prove unstable or where rock beds dipping towards the road at shallow angles show soft or weakened layers, retaining walls shall be constructed as directed by the engineer.
- Fracturing of final rock faces by blasting in side hill cut areas should be kept to a minimum by the use of split blasting techniques and low explosive powder factors.
- Fill slopes at slab culverts/pipe culverts shall be 1V:1.5H where this is different from the normal embankment slope the fill slopes shall be altered to suit over a distance of about 10 m either side of the culvert.
- Indicated widths of formation and carriageway are exclusive of extra widening at curves and Laybys.

NEPAL ELECTRICITY AUTHORITY
UPPER TRISHULI 3A HYDRO ELECTRIC PROJECT

UPGRADING EXISTING ROAD
TRISHULI COLONY TO CHAMPANI

DESIGNED BY :

DRAWN BY :

CHECKED BY :

APPROVED BY :

SCALE

NOT IN SCALE

TYPICAL SECTIONS

TYPICAL CROSS SECTION AND PAVEMENT DETAILS

DATE:

DRG NO : 3

SHEET NO : 7

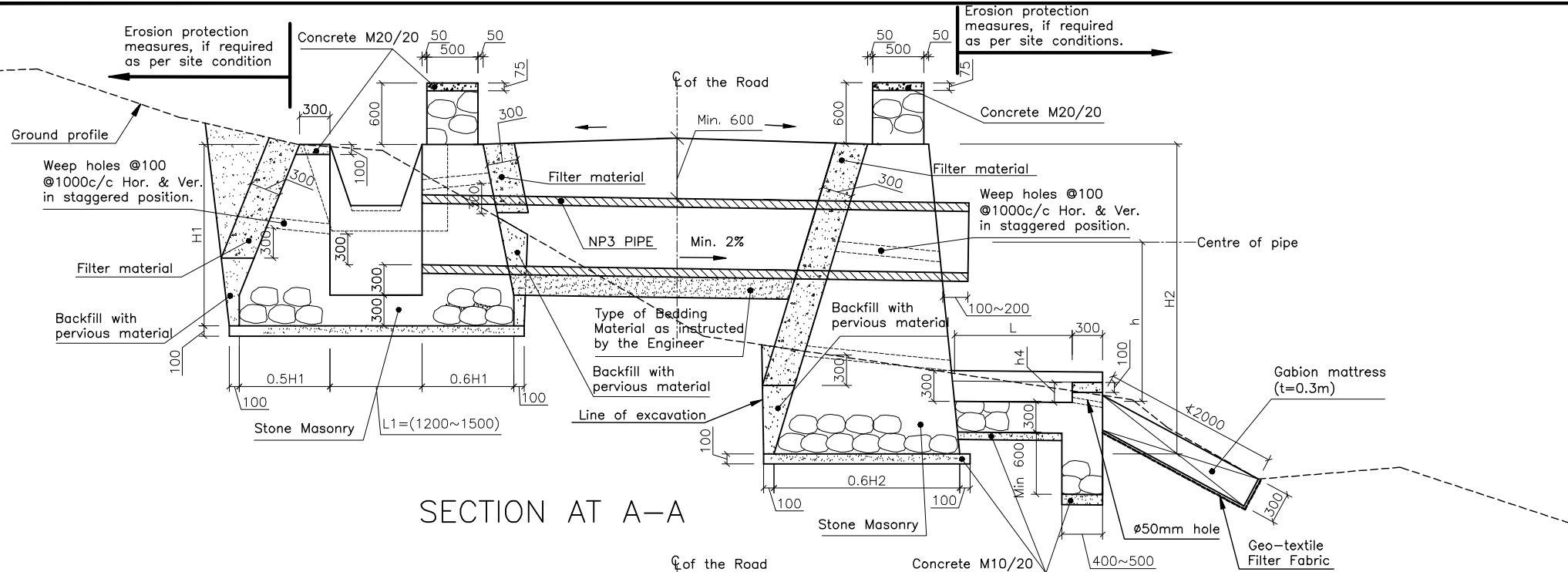
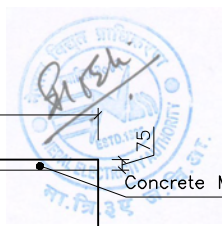

SECTION AT A-A

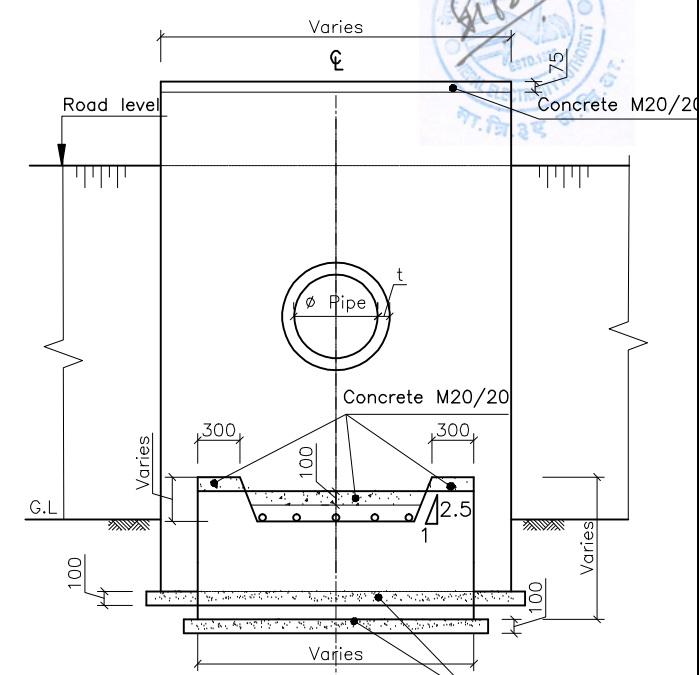

SECTION AT B-B

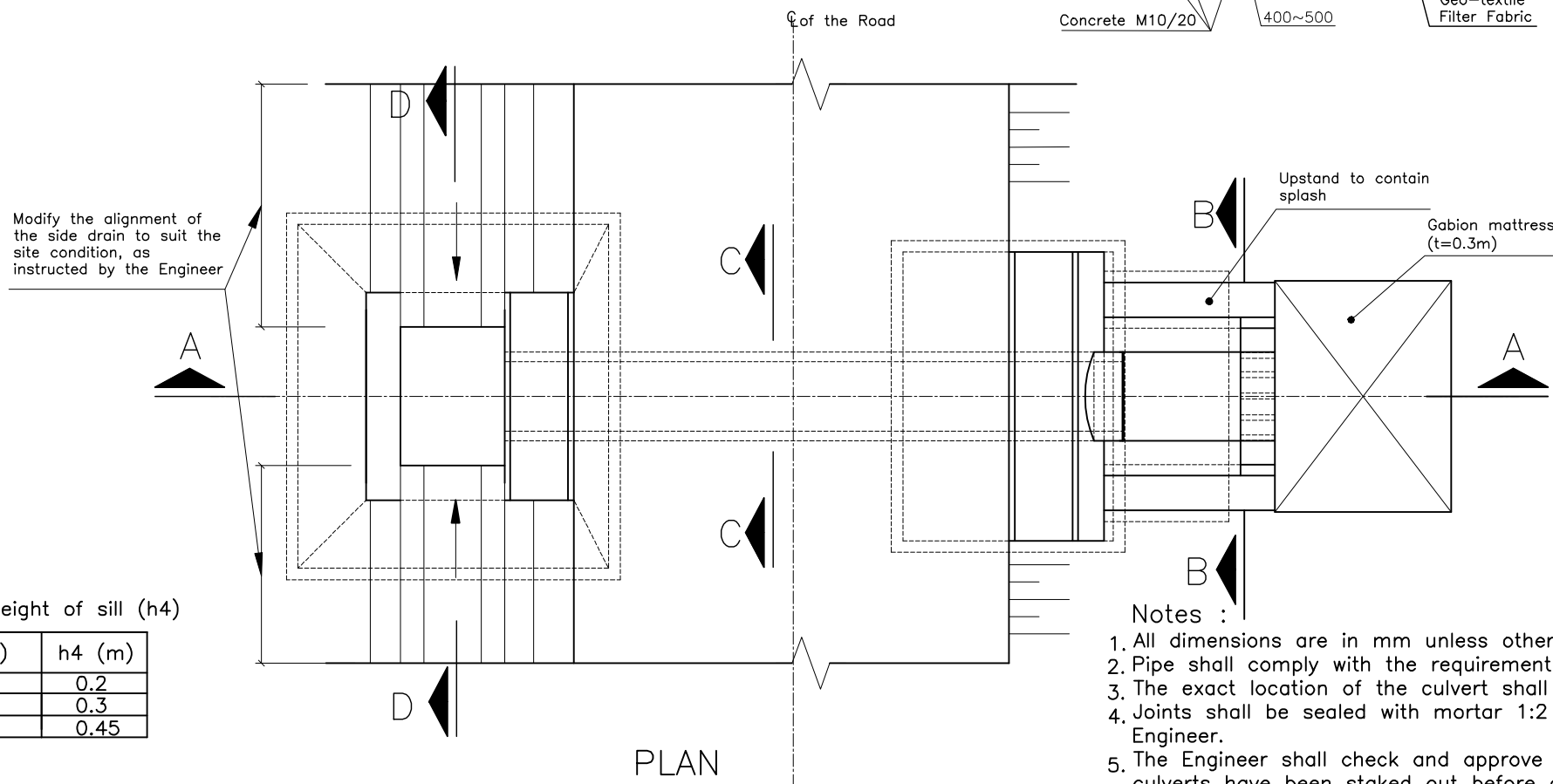

PLAN

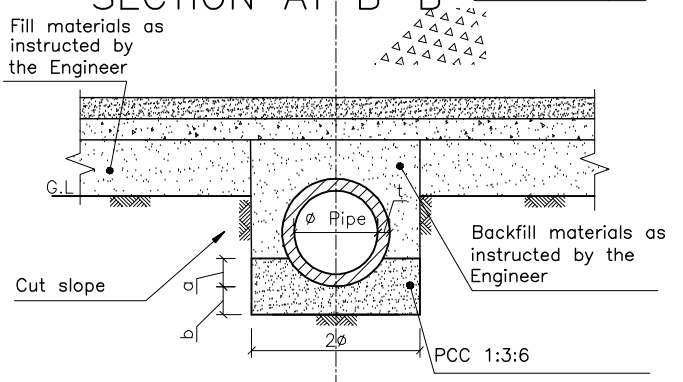

SECTION AT C-C

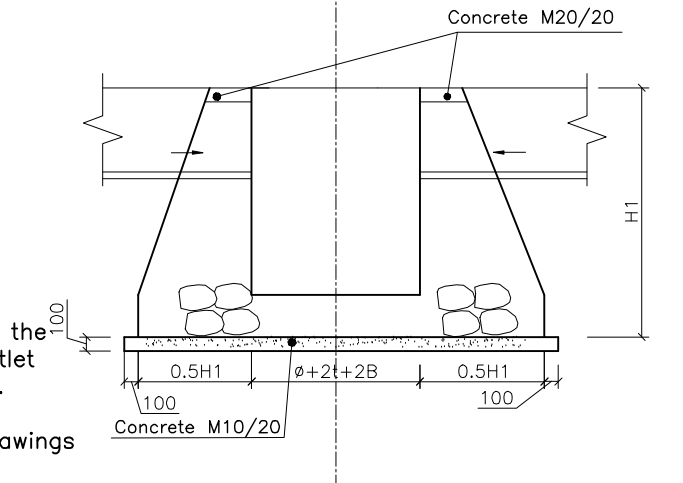

SECTION AT D-D

- Notes :
- All dimensions are in mm unless otherwise specified.
 - Pipe shall comply with the requirements of IS458:1988.
 - The exact location of the culvert shall be decided by the Engineer.
 - Joints shall be sealed with mortar 1:2 and sealing as directed by the Engineer.
 - The Engineer shall check and approve inlet and outlet elevations after the culverts have been staked out before construction starts. Inlet and outlet elevations shall be adjusted to suit the bed of existing creek or ditch.
 - Slope protection shall be placed as directed by the Engineer.
 - Riprap aprons at outlet and inlet shall be provided where shown in drawings or as directed by the Engineer.
 - All stone masonry shall be in cement sand mortar (CSM) grade 5 unless otherwise specified.
 - The dimensions may vary as instructed by the Engineer to suit the site conditions.
 - The Engineer shall check suitability of the soil condition before laying bedding.
 - L1 for $\phi 600=1200$ & for $\phi 900=1500$

Table: Height of sill (h4)

h (m)	h4 (m)
1.5	0.2
3.0	0.3
3.5	0.45

Table: Length of Base Slab (L) in mm.

h (mm)	1000	1500	2000	2500
300	700	900	1000	1100
600	1100	1300	1500	1700
900	1400	1700	2000	2200
1200	1700	2100	2400	2700
1500	2000	2400	2800	3100

Table: Height of the bedding materials in mm.

NP3 Pipe ϕ (mm)	B	a	b
150	75	100	150
200	100	100	150
300	150	150	200
600	200	200	200
900	250	300	200
1200	300	400	200

NEPAL ELECTRICITY AUTHORITY
UPPER TRISHULI 3A HYDRO ELECTRIC PROJECT

UPGRADING EXISTING ROAD
TRISHULI COLONY TO CHAMPANI

DESIGNED BY :
DRAWN BY :
CHECKED BY :
APPROVED BY :

SCALE
NOT IN SCALE

TYPICAL SECTIONS
DETAILS OF SINGLE PIPE CULVERT WITH
STONE MASONRY HEAD WALL IN CUT AND FILL

DATE:
DRG NO : **3**
SHEET NO : **8**

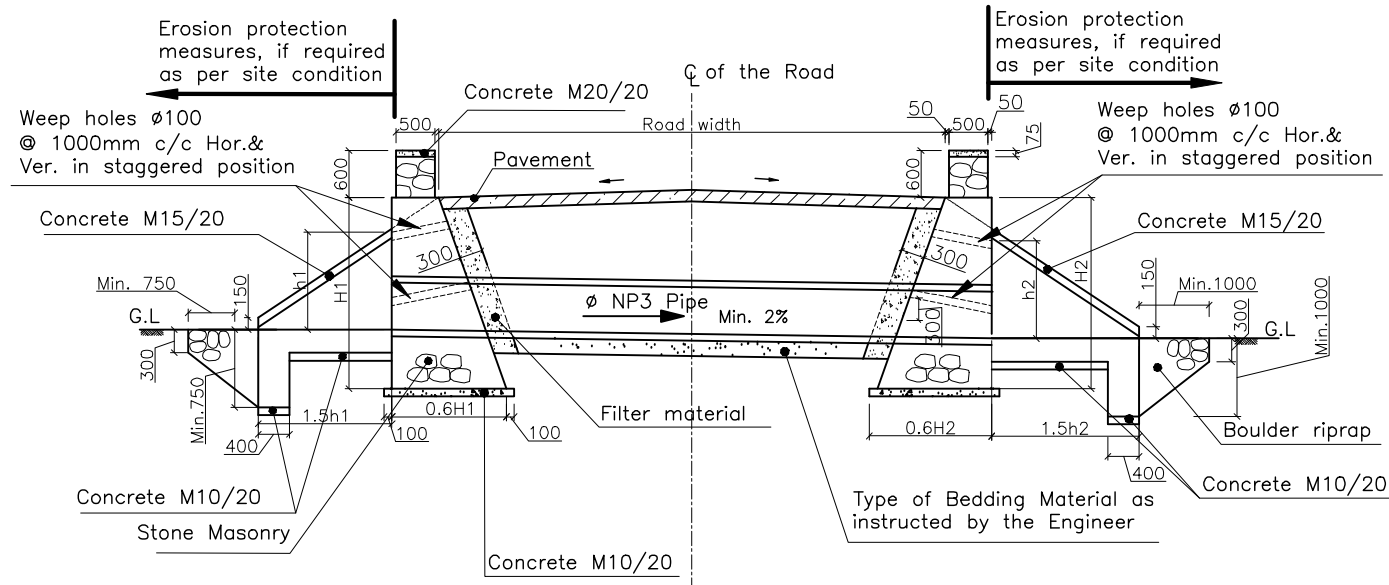

SECTION AT A-A

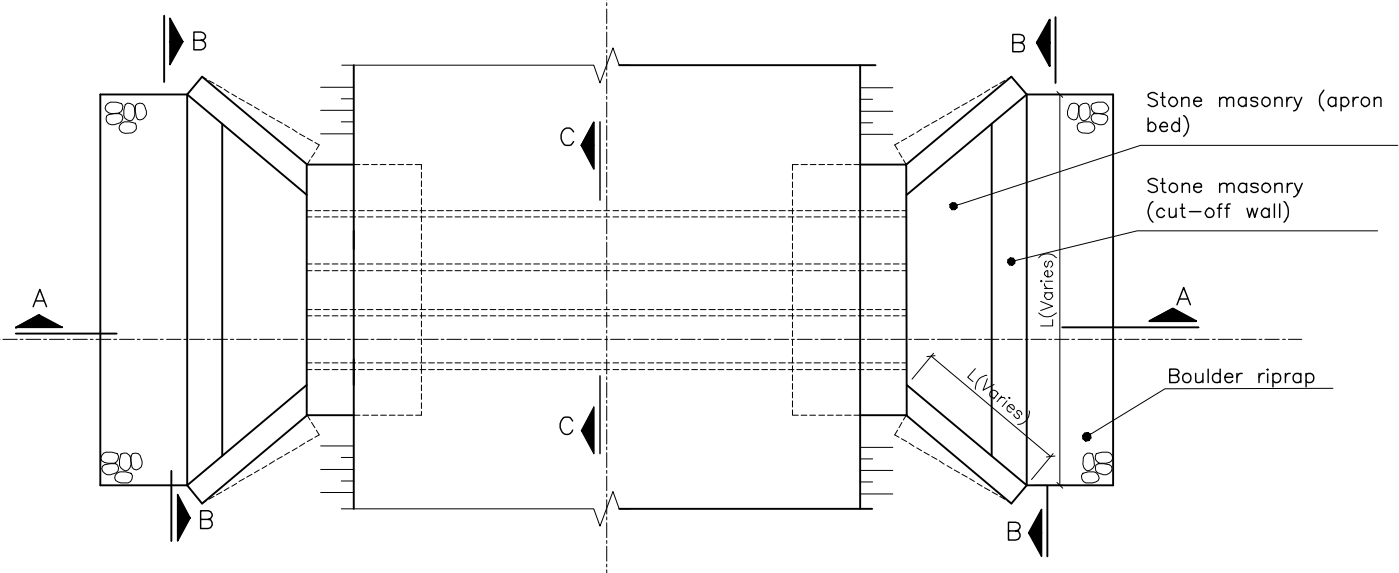

PLAN

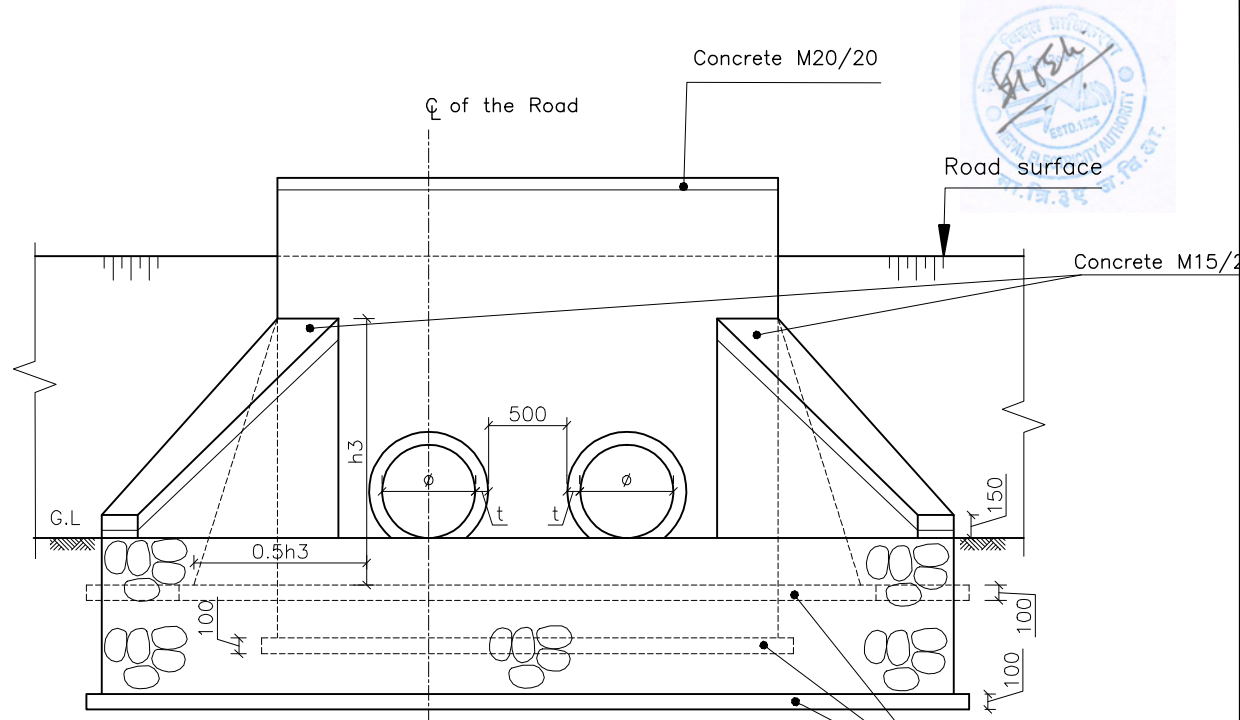

SECTION AT B-B

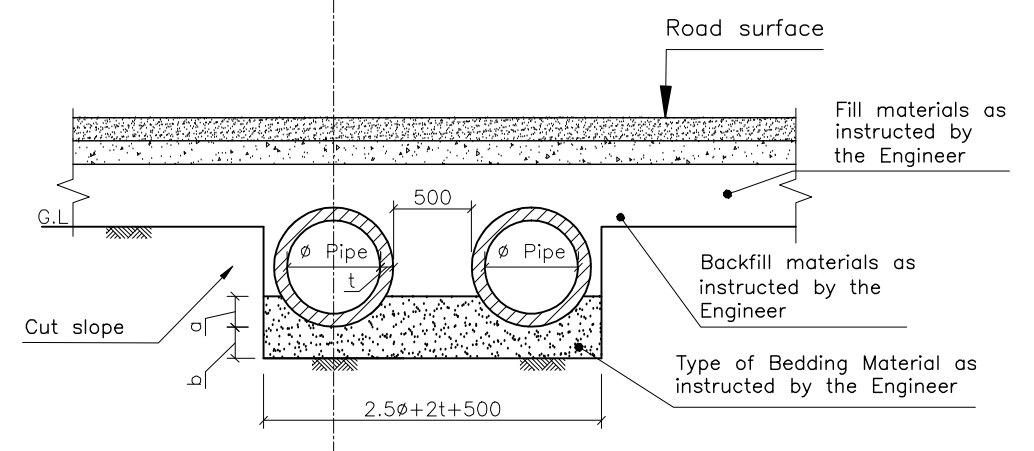

SECTION AT C-C

Notes :

1. All dimensions are in mm unless otherwise specified.
2. Pipe shall comply with the requirements of IS458:1988.
3. The exact location of the culvert shall be decided by the Engineer.
4. Joints shall be sealed with mortar 1:2 and sealing as directed by the Engineer.
5. The Engineer shall check and approve inlet and outlet elevations after the culverts have been staked out before construction starts. Inlet and outlet elevations shall be adjusted to suit the bed of existing creek or ditch.
6. Slope protection shall be placed as directed by the Engineer.
7. Riprap aprons at outlet and inlet shall be provided where shown in drawings or as directed by the Engineer.
8. All stone masonry shall be in cement sand mortar (CSM) grade 5 unless otherwise specified.
9. The dimensions may vary as instructed by the Engineer to suit the site conditions.
10. The Engineer shall check suitability of the soil condition before laying bedding.

Table:

NP3 Pipe ϕ (mm)	B	a	b
150	75	100	150
200	100	100	150
300	150	150	200
600	200	200	200
900	250	300	200
1200	300	400	200

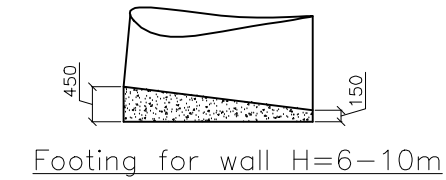
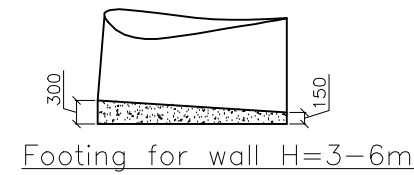
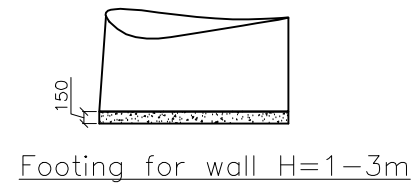

H (m)	b (m)	B (m)	Dry Stone (m3)
1	0.50	0.65	0.49
2	0.75	1.10	1.72
3	1.00	1.55	3.65

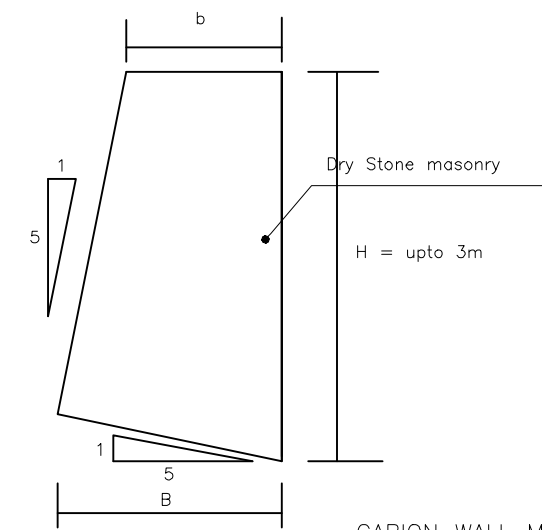
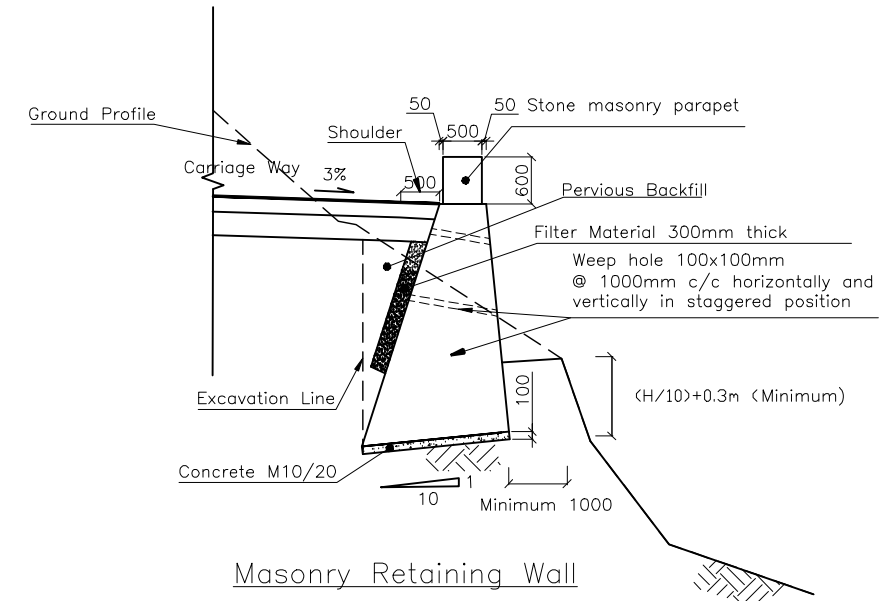

GABION WALL MEASUREMENTS

H(m)	1.0	2.0	3.0	4.0	5.0	6.0	7.0	8.0
BASE WIDTH (m)	1.0	1.5	2.0	2.5	3.0	4.0	4.5	5.0
X-SECTIONAL AREA (m ²)	1.0	2.5	4.5	7.0	10.0	14.0	18.0	22.5

Notes:

- All dimensions are in mm unless otherwise specified.
- Height and Base Width of the walls may vary as per site condition
- The sub soil water collected in drain pipe shall be discharged at the places decided by the Engineer.
- Backfill material shall be locally excavated free draining granular material or as otherwise instructed by the Engineer.
- Perforated pipe shall be provided where seepage of water is anticipated.
- Where masonry wall is to be extended/raised about 0.15m (in depth of one stone) thick stone masonry shall be removed from outer/top surface to provide bond with extended/raised portion.
- Where masonry wall to be raised top one layer of stone masonry of existing masonry wall shall be removed to provide bond with the raised portion.
- The Engineer shall satisfy himself with the condition of existing masonry wall and its foundation before extension/raising.
- The bond between existing and extend/raised masonry work shall be similar as in case of new masonry work.

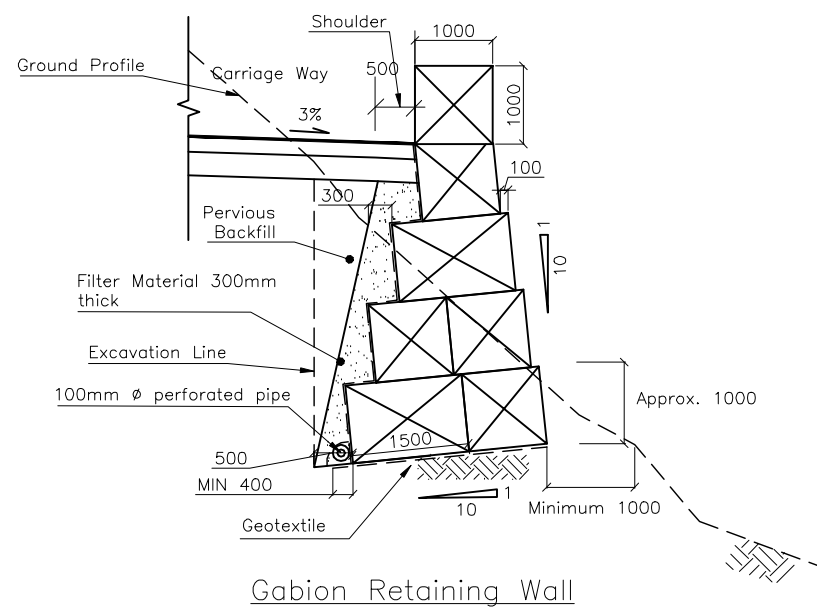

NEPAL ELECTRICITY AUTHORITY
UPPER TRISHULI 3A HYDRO ELECTRIC PROJECT

UPGRADING EXISTING ROAD
TRISHULI COLONY TO CHAMPANI

DESIGNED BY :

DRAWN BY :

CHECKED BY :

APPROVED BY :

SCALE

NOT IN SCALE

TYPICAL SECTIONS

TYPICAL RETAINING STRUCTURE DETAILS

DATE:

DRG NO : 3

SHEET NO :10